

A Review of Automatic Generation Control for Multi-Region Interlinked Electricity System

G. N. Obiora*, O. P. Adetunji

Department of Electrical, Electronic & Telecommunication Engineering, Bells University of Technology, PMB 1015, Ota, Ogun State, Nigeria

*corresponding author's email: gnbiora@bellsuniversity.edu.ng

Abstract – *Automatic Generation Control (AGC) is critically important for the frequency control and tie-line power flow regulation of modern energetic and interlinked electricity systems. AGC is of fundamental importance because of the added sophistication of power networks arising from renewable energy sources integration and multiple control area interconnections. This paper presents a selected survey of standalone and hybrid control techniques executed between 2001 to 2025, all aimed at achieving AGC especially in multi-region interlinked systems. The selected control methods comprise of the combination of classical control methods: like Proportional-Integral (PI) and PI-Derivative (PID) controllers, soft computing or intelligent methods as well as those that are metaheuristic based: like Firefly Algorithm (FA), Artificial Neural Network (ANN), Fuzzy Logic (FL), Particle Swarm Optimization (PSO), Genetic Algorithm (GA), and other associated approaches. Furthermore, this paper provides up to date information on the primary issues and advancements that require attention for reliable and intelligent AGC implementation, and will be relevant to enthusiasts and stakeholders in this area.*

Keywords: *Automatic generation control, classical control methods, frequency control, interlinked electricity systems, soft computing and metaheuristic methods*

Article History

Received 24 December 2025

Received in revised form 11 February 2026

Accepted 19 February 2026

I. Introduction

The stability, dependability, and cost-effective operation of large-scale power systems depend heavily on efficient control procedures, particularly for multi-area linked systems. These systems are made up of tie-lines connecting many generating regions. Each region must manage and balance its load and generation in accordance with established power exchange schedules [1].

One of the most difficult problems in electricity system control is undoubtedly managing huge, interlinked power systems while considering their growing size, complexity, and the frequent, unpredictable disturbances that occur during operation. Additionally, the demand side's power consumption varies endlessly and suddenly. Variation in the load need in any control region causes a temporary variation in the frequency, power production, and tie line power flow across the whole system [2].

Therefore, the main reason for these variations is the discrepancy between the sudden demand for power and production. After a load disturbance, tie-line power and frequency flowing between interlinked locations must rapidly return to their scheduled values in order for power

systems to be stable, dependable, and secure [2]. By balancing the power produced against the demand + losses, this is achieved.

AGC is a control system that enables synchronous generators to adjust their generation in reaction to load needs. This ensures that tie-line power and area frequency errors/oscillations converge to zero. An improperly designed AGC can cause significant oscillations in the area frequency, tie line power flows and generation, which can impair system performance and push the system toward loss of synchronism and instability [2].

The main role of AGC is to guarantee the effective and seamless operation of an electricity system. Maintaining the power exchange at the desired level and keeping the operating frequency of the various control zones of a multi-area interlinked system within specified bounds are the objectives of AGC. Interlinked systems are made up of several geographically separated electricity system areas that are interlinked by tie lines for economic reasons, and increased supply reliability. The dynamic interactions between these areas simultaneously add to the intricacy of dealing with load and frequency changes, as well as variations of power output from the tie-lines [3],[4].

This is an Open Access article distributed under the terms of the Creative Commons Attribution-Noncommercial 3.0 Unported License, permitting copy and redistribution of the material and adaptation for commercial and uncommercial use.

Large multi-region linked electricity systems also benefit from AGC at the secondary control layer. If the active power generated falls short of the power demand due to abrupt disruptions or other factors, the frequency of the power production units will drop, and vice versa. This will cause the system frequency to deviate from its nominal value. But on employing AGC, the frequency variation will be rapidly dampened, and the tie-lines power maintained at its planned level [3],[4].

Furthermore, the integration of Renewable Energy Sources (RESs) like solar, tidal turbines and wind into multi-area hybrid electricity systems has increased in recent years, and power grids are becoming increasingly complicated. Likewise, the introduction of novel strategies such as smart grids and micro-grids has made contemporary electricity grids more unpredictable and complex [5].

For the AGC of countless interconnected power systems, numerous researchers have investigated a variety of control strategies. The primary aim of these investigations was to employ a control algorithm to enhance system performance by reducing frequency fluctuations and regulating tie line power flow variations. Despite the fact that the Load Frequency Control (LFC) system performance was enhanced by majority of the control schemes, the controller still needs to be readjusted each time a perturbation occurs [6].

In order to regulate tie line power and frequency variations, traditional controllers like PID controllers have been employed. Although conventional controllers are well-studied and have a straightforward design, their applications are limited by flaws such as their poor dynamic response, extended settling time, erroneous results, and reliance on trial-and-error methods. In place of traditional integral controllers for AGC, fractional order PID controllers have also been suggested [5], [6].

The primary disadvantages of fractional order controllers are their complexity and higher processing demands. H-infinity controllers, sliding mode controllers, and model predictive regulation mechanisms are some of the other sophisticated control strategies that have been suggested in literature. These controllers have the disadvantages of being complicated, having unpredictable performance, and not being widely used in the industry [5], [6].

To improve PID gain parameters, heuristic approaches like GA, PSO, Differential Evolution (DE) algorithm, FA, and Grey Wolf Optimization (GWO) algorithm have been employed. However, these optimization techniques are mostly used in traditional power systems without considering power networks incorporated with RESs or any of the non-linear constraints of the system's constituent parts. Cascaded controllers, which are made up of two controllers with one placed inside the other's feedback loop and the result of the first serving as the second controller's set-point, have been introduced by numerous researchers [5], [6].

The cascaded controllers' lengthy design, high tolerance requirements, and time consumption are their main disadvantages. ANN controllers have been utilized to update training sets based on continuous learning, and advancements in Artificial Intelligence (AI) has heightened [5], [6].

AGC in interlinked hybrid power systems has been accomplished by ANN-based controllers employing a variety of methods like ANN-tuned PID controllers and fractional order ANN controllers. Meanwhile, as a result of its quick response and comparatively broad application, the FL approach to system dynamics control has garnered more attention from researchers. There are now Adaptive Neuro-Fuzzy Inference System (ANFIS) and FL controllers. Although significant skill is required to tune the membership functions in a fuzzy system alone. Consequently, a number of other published works based on AGC of interconnected power systems have been produced [5], [6].

This paper provides selected assessment of standalone and hybrid AGC control methods applicable in interconnected systems. Discussed also, are recent research trends and emerging challenges relating to the utilization of AGC in modern electricity system. The order of the succeeding sections is as follows: section 2 - overview of AGC, section 3 - multi-area interlinked power system, section 4 – assessment of past studies, and section 5 - conclusion.

II. Overview of Automatic Generation Control

Electricity system stability refers to its ability to regain its operating equilibrium after a perturbation and to sustain it under typical operating conditions. Stability of an electricity system can be classified based on voltage, frequency and rotor angle. Variations in active power, which largely affects system frequency, or useless power, which primarily affects voltage magnitude, can cause disturbances that are either short-term or long-term [7].

In an interlinked electricity system, tie line power and area frequency interchange vary in tandem with load demand. Significant variations in frequency have the potential to disrupt system protection procedures, underload or overload transmission lines and eventually cause the power system to fail. As a result, frequency variation in a power network can be addressed using AGC [7].

Three degrees of frequency control are distinguished: primary, secondary, and tertiary. The most common method for implementing the main frequency control is governor droop and it leads to Steady State Errors (SSEs). The tertiary regulation level is attained by re-dispatching production units and ancillary reserve following a significant disruption, whereas secondary frequency regulation is also referred to as AGC [7].

Globally, the number of interlinked power networks is constantly increasing due to the demand for electricity, particularly as RESs is now more widely used. Typically, interregional tie-lines connect multiple control areas or interlinked subsystems that make up large power networks. The entire linked grid will enter an unstable operating condition causing the tie-line power and frequency to vary when a sudden power variation event takes place, and this will have a substantial effect on the power balance in each subsystem [8].

AGC can thus be deployed to address such imbalance [8]. There are two primary AGC components: LFC and Automatic Voltage Regulator (AVR) loops, and both are depicted in Fig. 1. Generator, governor, turbine and load are other parts. Controlling frequency variations, sustaining the recommended values for power exchange and monitoring load requirements in linked power systems while supplying a SSE of zero are among the roles of LFC [9]. The Area Control Error (ACE), a control error signal, is measured in order to meet the LFC objectives. The actual power imbalance between the supply and the load is represented by this signal, which is a linear mix of frequency variation and net interchange. In interlinked power systems, the AVR is the central component of the excitation control and it is responsible for voltage regulation and transient stability improvement [10], [11].

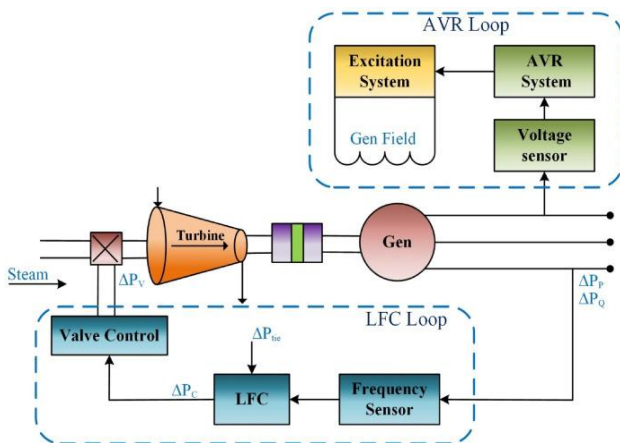

Fig. 1. Schematic diagram of Automatic Generation Control [9]

Where: ΔP_p is change in active power, ΔP_q is change in reactive power, ΔP_{tie} is power change in the tie line, ΔP_c is power change due to the controller, ΔP_v is power change due to the valve control

A. Load Frequency Control

In order to sustain the constituted interchange with other regions within predefined limits or the schedule's system frequency, LFC regulates the power output of controllable generators within a designated region in reaction to changes in tie-line loading, system frequency, or a relationship between the two. Maintaining equilibrium between real power production and

consumption is crucial for the proper operation of the interlinked electricity system [12], [13].

B. Automatic Voltage Regulator

The excitation regulation of generators is a significant subject in the realm of electricity systems. Good excitation management has proven to be very effective and helpful in enhancing transient stability, which in turn minimizes fluctuation of the voltage on a power system [14], [15], [16].

AVR is a crucial part of power systems that uses excitation control to control voltage. It is nothing but regulation of system voltage by influencing the wattless power balances in the power network. This technique is otherwise called reactive power control loop. To keep the generator's terminal voltage or output constant, AVR modifies the excitation system's terminal voltage. In this manner, the field current of the generator is adjusted [14], [15], [16].

Additionally, this situation alters the produced Electromotive Force (EMF). The generator's power production is tuned to a novel, stable level while maintaining the intended terminal voltage. AGC and voltage regulation are required in large, interlinked power systems since human regulation is very difficult. AVR assists with AGC by keeping the terminal voltage of the generator at acceptable levels [14], [15], [16].

C. Governor

Typically, the governor controller controls the generator's energy production through control signals that act on the gates or valves to vary the mechanical power of the turbine, which in turn alters the generator's generating capacity, and is typically maintained at a predetermined value. The governor is thus a system that instantly and automatically adjusts the generator's speed of rotation according to the frequency deviation, helping to reinstate the frequency to the nominal value of the power system [17].

D. Turbine

In electricity systems, turbines are utilized to transform the energy from moving fluid like water or steam, into mechanical power that can be fed into a generator seamlessly. The response rates and dynamics of various turbine types: gas, steam, and water must be considered while designing an AGC. In control systems, each can be modelled and developed using transfer functions [18].

E. Generator

After converting the mechanical power from the turbines into electrical power, generators work in tandem with the grid, their speed being correlated with the

frequency of the system. AGC controls the generator output to preserve equilibrium between the power produced and the load's power requirements. In order to restore system stability, generators respond to variances by using primary control to stabilize frequency and follow AGC signals for secondary control [18].

F. Load

Interconnected electricity networks are linked to a variety of electrical gadgets which constitute a load. Furthermore, load refers to the power used by residential, commercial, and industrial customers, and it fluctuates constantly due to factors like user behavior and weather. These changes can cause imbalances between generation and demand, resulting to frequency variations. To maintain system stability arising from such variations, AGC is employed [18], [19].

III. Multi-area Interlinked Power System

The concept of interconnecting multiple electricity systems or control areas has been a key advancement in power grid operation. In order to reliably and economically supply electricity to the loads, electric power system networks are extensively integrated. Systems for distribution, transmission, and generation are all part of a linked electric power grid. Various electric power sources like RESs and non-RESs make up the electricity produced by generation plants [20], [21].

A multi-area power network refers to a set of geographically separated regions or control areas that are linked through transmission lines with high voltages, enabling power exchange between them. Load centers and electrical power generation facilities are typically located far apart. Power supply to the load centers requires power grid connectivity and power flow regulation. This interconnection although beneficial is not without its unique challenges especially with the increased integration of RESs. This thus, needs to be addressed to ensure reliable and stable operation of such interlinked networks [20], [21].

In a power system, it is expected that every generator should function as a cohesive unit. This implies that a comparable generator, governor and turbine system can be used in place of each area. Each region supplies power to its user pool, and tie line power facilitates the exchange of electricity across the connected regions. Fig. 2 depicts the model diagram of a three-region network. Since tie-lines and ACE are important terms with respect to interlinked systems, both are subsequently explained in the succeeding subsection of this section [9], [22].

A. Tie-lines

With the help of tie lines, different regions can be linked to each other via one or multiple transmission lines in an interlinked electricity grid. There is power exchange between two regions linked by tie lines when their frequencies are totally distinct [18].

Considering a two-area network (i and j) for instance, the power as a result of tie-line trades in region j and region i is ΔP_{tieij} and synchronizing torque coefficient of their tie-line is given as (T_{ij}) [18].

Consequently, we may also state that the integral of the frequency deviation (ΔF_i and ΔF_j) among the two regions is an error in the power arising from the tie lines [18]. The mathematical expression for the tie-line power flow in Laplace transform vis-a-vis Fig. 2 and considering two-areas, is given [9] by Equation (1).

$$\Delta P_{tie,ij}(s) = \frac{2\pi}{s} T_{ij} (\Delta F_i(s) - \Delta F_j(s)) \quad (1)$$

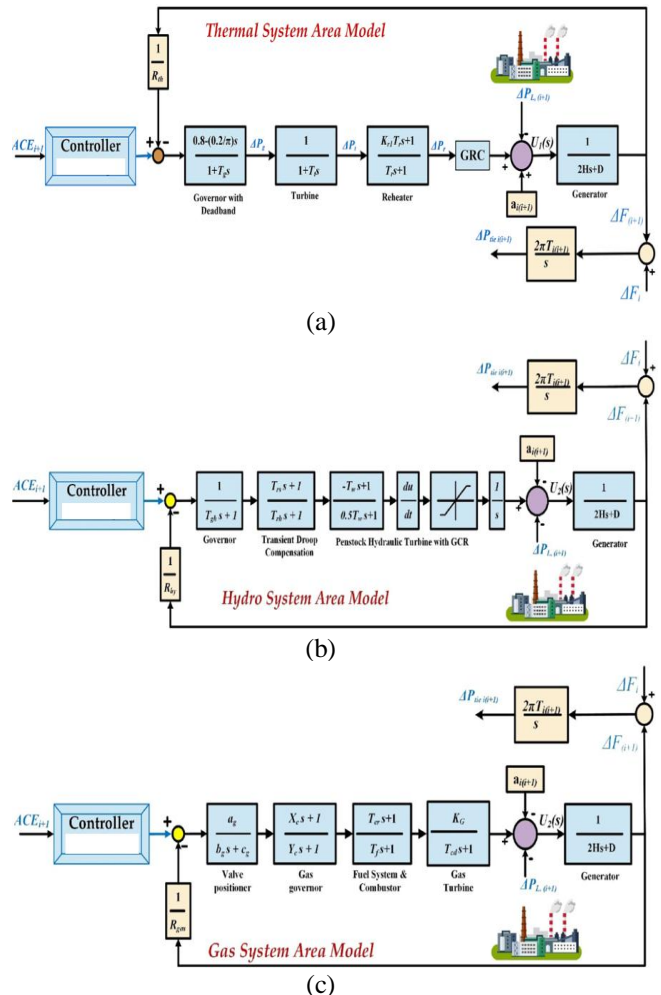

Fig. 2. Model representation for: (a) Thermal system area; (b) Hydropower system area; (c) Gas power system area [9]

Fig. 3 depicts a typical representation of the tie lines of a 3-area interlinked electricity network.

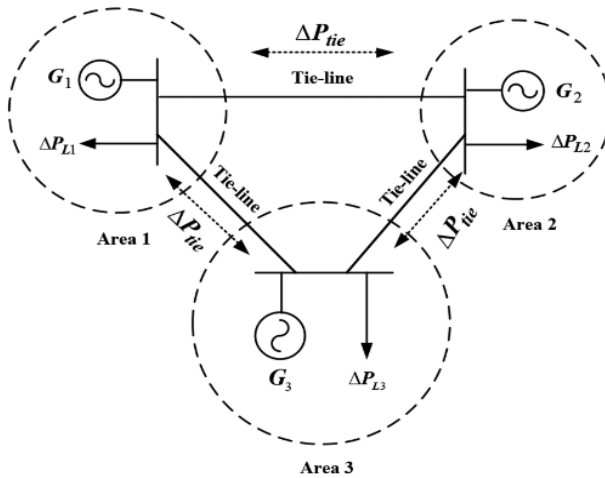

Fig. 3. Three-area interlinked electricity network with their corresponding tie line [23]

Where G and ΔP_L [9] denotes generator and change in load respectively.

B. Area Control Error

ACE signal is regarded as a plant's output in each of the power producing regions. All frequency and errors of the tie line power in the system are set to zero by setting the ACEs to zero in every location. Therefore, for any location under consideration, the ACE is a mix of the tie line power and frequency adjustments [18], [22]. ACE for a given area i can be represented [5] by Equation (2).

$$ACE_i = \Delta P_{tie} + B_i \Delta f_i \quad (2)$$

Where B_i is the bias parameter of area i and given as Equation (3).

$$B_i = D_i + \frac{1}{R_i} \quad (3)$$

D_i and R_i denotes frequency dependency of load and regulation parameter of the turbine-generator unit.

IV. Assessment of Past Works

The development of AGC in multi-area interlinked electricity networks has progressed from classical control methods to more sophisticated intelligent and hybrid optimization strategies due to the heightened complexity and nonlinearity of the systems, as well as addition of RESs. Diverse studies have been executed with remarkable success in the area of AGC. Thus, selected studies executed from 2001 to 2025 was analyzed in this

section.

Classical control strategies are methods utilized to design, analyze, and improve the behaviour of control systems such as AGC. They help ensure that a system performs as expected by adjusting its response to external inputs and disturbances. The primary goal of these techniques is to achieve stability, accuracy and fast response while maintaining robustness against uncertainties [24].

Thus, classical control techniques are the basic building blocks of AGC systems [24]. These techniques are called classical because they were developed before modern regulation theories such as state-space methods and adaptive regulation. Despite being older, they remain widely used because they provide intuitive graphical methods and mathematically straightforward approaches for analyzing and designing controllers. As a result of its ease of execution, the PI controller is the most popular classical controller for resolving AGC problems. However, while considering the system's performance and stability requirements, the PID regulator provides a sufficient system response [12], [24], [25].

Almost twenty years ago, the idea of intelligent control (IC) was initially presented. With a wide range of industrial applications, IC has become one of the most active and productive research and development (R&D) fields across engineering disciplines in recent years. Then, many model-based control solutions have been presented by scholars in the past forty years. These design methodologies often encompass a number of stages, including designing, investigation, simulation, execution, and confirmation. Many of these techniques have been physically executed and have successfully solved a variety of complicated problems under a range of uncertainty [26], [27].

From a wide standpoint, Soft Computing (SC) is based on intelligent systems. The main goal of calculations in classical hard computing are certainty and accuracy. But in soft computing, accuracy and certainty come at a price. Hence, in order to provide a framework for the tradeoff between uncertainty and precision, it is reasonable to think of the incorporation of reasoning, computation and decision making as different partners in a pool. The theoretical design and execution of intelligent systems are made possible by this methodological integration. Adaptability, reasoning, handling complicated dynamics, flexibility, uncertainty management and learning are other factors that contribute to a system's intelligence. GAs, FL, probabilistic reasoning and NN computing are the main collaborators in this type of partnership. Additionally, rather than being competitive, these approaches are generally complementary. They are also increasingly utilized in combination, which is known as hybrid [26], [27].

In order to enhance AI and integrate human expertise into computing operations, soft computing frameworks and their combinations are frequently employed. Their use

includes managing complicated systems with unknown characteristics and designing intelligent autonomous controllers or systems for accomplishing a predetermined objective, such as AGC. These frameworks have demonstrated the capacity to interpret data, adjust to shifting environmental circumstances, and absorb environmental knowledge. SC approaches differ from analytical approaches in a number of significant ways [26], [27].

Firstly, they can learn from experience; second, they can be extended into fields where firsthand knowledge is not available; and thirdly, they can map inputs to outputs more quickly than analytical representations that are inherently serial thanks to parallel computer architectures that mimic biological processes [26], [27]. Table 1 shows the comparison of the considered studies.

TABLE I
COMPARISON OF PAST STUDIES

Reference & Year	Technique	Controller Type & Optimization Method	System Size	RES Integration	Some of the Performance Indices Considered	Strength & Limitation	Application
[33], 2001	ANN	Controller type: ANN-based controller Optimization method: back propagation	Two-region interlinked power system	None	Tie-line power deviation, frequency deviation	Strength: the controller can handle parameter oscillations and non-linearities without needing a mathematical model Limitation: controller dependence on large amount of training dataset	LFC
[50], 2010	Robust tuning method	Controller type: PID controller Optimization method: Contours of Nichols chart and maximum peak resonance specification-based tuning	Two-machine system	None	Tie-line power deviation, frequency deviation	Strength: Utilization of an enhanced PID controller Limitation: may not be able to capture cases of extreme non-linearities	LFC for power grids with high domination of hydroelectric generation
[39], 2014	Metaheuristic optimization using FA	Controller type: Integral Derivative with Filter (IDF) controller Optimization method: FA	Three-region interlinked power system	None	Comparison of the performance of different controllers – IDF, ID, I, PI, PID	Strength: Better convergence characteristics of the FA and high frequency noise suppression by the filter Limitation: high computational cost associated with the utilization of metaheuristic optimizations like FA	LFC in power systems with mixed generation sources
[30], 2016	Modelling and simulation	Controller type: PID controller Optimization method: trial and error approach was utilized for tuning	Three-region interlinked power system	None	Tie-line power deviation, frequency deviation	Strength: reliability and ease of implementation of PID controllers Limitation: susceptibility of the controller to sudden changes in the system	LFC
[34], 2016	Integral sliding mode control (SMC) with neural networks	Controller type: integral SMC Optimization method: SM based-neural networks utilization for suppression of uncertainties	Two-region interlinked power system	Wind energy	Tie-line power deviation, frequency deviation	Strength: insensitivity to matched uncertainties by SMC Limitation: chattering effect associated with SMC	LFC for power grids with high penetration of wind energy

Reference & Year	Technique	Controller Type & Optimization Method	System Size	RES Integration	Some of the Performance Indices Considered	Strength & Limitation	Application
[45], 2016	FL control incorporated with metaheuristic optimization	Controller type: fuzzy PID regulator Optimization method: FA	Multi-region multi source power system	Indirect – inclusion of Unified Power Flow Controller (UPFC) in the tie line and Superconducting Magnetic Energy Storage (SMES) units in the considered regions	Tie-line power deviation, frequency deviation	Strength: addition of SMES/UPFC aided in the reduction of oscillations Limitation: computational intensiveness involved - FL, PID, UPFC/SMES was combined	Advanced grid management for large scale interlinked power systems
[46], 2016	Simulation of transactions using DISCO Participation Matrix (DPM)	Controller type: optimal PI regulator Optimization method: full state feedback control strategy	Two-region interlinked power system	None	Tie-line power deviation, frequency deviation, settling time, peak under/overshoots	Strength: utilization of shunt AC/DC tie-lines aided in dampening of oscillations Limitation: the PI controller may struggle to maintain optimal operation in high non-linear environments	Designed for utilities operating in environments where distribution firms can choose their power suppliers across regional borders
[47], 2016	Hybrid fuzzy PID regulator with Derivative Filter (PIDF)	Controller type: mixed fuzzy PID regulator Optimization method: FA	Four-region interlinked power system	None	Tie-line power deviation, frequency deviation	Strength: satisfactory performance of the suggested regulator under variation of system parameters & loading conditions Limitation: the strength of FA depends on the algorithm control parameters like number of fireflies, absorption coefficient, attractiveness and randomization.	LFC of multi-linked power system under deregulated environment
[41], 2018	Metaheuristic optimization using FA	Controller type: FA based-PI regulator Optimization method: FA	Two-region interlinked power system	Solar-PV	Integral Time Squared Error (ITSE), Integral Absolute Error (IAE), Integral Time Absolute Error (ITAE), Integral Squared Error (ISE), settling time	Strength: effective LFC of a mixed system using a well-tuned PI regulator Limitation: although optimization was applied, PI controllers have slow transient response to disturbances	LFC of RES + conventional energy source
[31], 2019	Mixed intelligent control	Controller type: PID regulator Optimization method: PSO based-ANN	Microgrid system	Wind energy + solar PV	Frequency deviation, settling time, overshoot	Strength: easy implementation of the suggested method for LFC Limitation: high computational cost burden associated with the mixed intelligent system	LFC for freestanding microgrids (MGs)

Reference & Year	Technique	Controller Type & Optimization Method	System Size	RES Integration	Some of the Performance Indices Considered	Strength & Limitation	Application
[48], 2019	FA based NN control & PID control	Controller type: PID regulator Optimization method: FA	Two-region interlinked power system	None	Tie-line power deviation, frequency deviation	Strength: the FA based NN regulator ensures enhanced transitory response of the system Limitation: computational cost burden of the suggested technique	LFC in power systems needing high precision non-linear control
[35], 2020	ANN based SMC	Controller type: SMC Optimization method: ANN	Two-region & three-region interlinked power system	None	Tie-line power deviation, frequency deviation	Strength: negligible frequency variations with little under/over shoots was attained in addition to enhanced system dynamics Limitation: high level control theory knowledge is required in order to effectively deal with the computational cost burden of the approach	For power grids requiring high-level control
[22], 2020	ANN based control	Controller type: ANN regulator Optimization method: ANN	Three-region interlinked power system	None	Tie-line power deviation, frequency deviation	Strength: effective reduction of frequency deviation and tie line power fluctuation caused by load perturbations Limitation: high computational demand linked with the ANN method	AGC of interlinked electricity systems
[32], 2021	ANN based-PI control	Controller type: PI regulator Optimization method: ANN	Two-region interlinked power system	None	Frequency deviation	Strength: enhanced dynamic frequency response under load variations Limitation: dependency of the ANN on the training dataset for gain tuning	Adaptive LFC
[44], 2021	Magnetotactic Bacteria Optimization (MBO)	Controller type: Integral-Double-Derivative (IDD) regulator Optimization method: MBO + FL	Three-region interlinked power system	Solar thermal power plant	Tie-line power deviation, frequency deviation	Strength: effective control of tie-line and frequency power exchange with the study's approach Limitation: high computational burden associated with the proposed method	For control of power grids with infrastructure that supports electric vehicle utilization
[49], 2021	Metaheuristic optimization using hybrid Gravitational Search with FA (hGFA)	Controller type: PI regulator Optimization method: hGFA	Two-region interlinked power system	None	Tie-line power deviation	Strength: shorter settling times and better LFC was attained using hGFA Limitation: high computational burden associated with the method proposed	LFC for hydrothermal power networks

Reference & Year	Technique	Controller Type & Optimization Method	System Size	RES Integration	Some of the Performance Indices Considered	Strength & Limitation	Application
[6], 2022	Simulated Annealing (SA)	Controller type: PID-FL regulator Optimization method: SA	Two-region interlinked power system	None	Tie-line power deviation, frequency deviation	Strength: effective dampening of tie-line power & frequency variations with the proposed method Limitation: the slow convergence feature of SA	AGC for interlinked power systems
[37], 2022	JAYA optimized Model Predictive Control (MPC)	Controller type: MP regulator Optimization method: JAYA algorithm	Three-region interlinked power system	Wind energy and solar PV	ITSE, IAE, ITAE, and ISE	Strength: lower overshoot & fast frequency response was achieved Limitation: computational burden of the MPC	AGC of power systems incorporated with RESs
[42], 2022	Adaptive control	Controller type: adaptive PI regulator Optimization method: Not specified	Two-region interlinked power system	Solar PV & Wave Energy Conversion System (WECS)	IAE, ITAE, ISE	Strength: enhanced system response was attained Limitation: accurate estimation of system parameters is required for adaptive action	Adaptive LFC for power grids incorporated with RESs
[28], 2023	Integration of Linear Quadratic Regulator (LQR) + damping compensator + P regulator	Controller type: LQR-based proportional damping compensator Optimization method: LQR	One area power system	None	SSE, settling time, frequency deviation	Strength: reduction of settling time & frequency variations was attained Limitation: expert knowledge of the LQR method is needed	LFC
[29], 2023	Swarm intelligence optimization	Controller type: PID regulator Optimization method (OP): Artificial Bee Colony (ABC)	Three-region interlinked power system	None	Tie-line power deviation, frequency deviation	Strength: the global search capability of the ABC OP method Limitation: slow convergence of the ABC OP method	LFC
[38], 2023	Enhanced Gradient Based Optimizer (EGBO)	Controller type: PID regulator Optimization method (OP): EGBO	Two-region interlinked power system	None	ITAE	Strength: latency, precision, & resilience of EGBO compared to other methods Limitation: EGBO requires accurate tuning for optimal operation	AGC
[36], 2024	NN-MPC	Controller type: MPC Optimization method (OP): Levenberg-Marquardt	Two-region interlinked power system	None	Tie-line power deviation, frequency deviation	Strength: NN-MPC superior steady state & transient response under variation of system parameters Limitation: black box nature of NN-MPC	LFC
[40], 2024	Comparative control analysis	Controller type: adaptive PID (APID) regulator Optimization method (OP): gradient descent	Six-region interlinked power system	Solar PV & wind energy	Tie-line power deviation, frequency deviation	Strength: provision of valuable insights for reduction of perturbations in power systems Limitation: computational time for parameter tuning linked with the APID	AGC for interlinked power systems

Reference & Year	Technique	Controller Type & Optimization Method	System Size	RES Integration	Some of the Performance Indices Considered	Strength & Limitation	Application
[43], 2024	ANFIS	Controller type: ANFIS regulator Optimization method (OP): backpropagation & least squares estimation	One area power system	None	Frequency deviation	Strength: resilient variations damping was attained with the ANFIS Limitation: computational cost burden of the ANFIS method	LFC
[53], 2024	Swarm intelligence optimization	Controller type: Rat Swarm Optimization (RSO)-based PID regulator Optimization method (OP): RSO	One area power system	None	Frequency deviation	Strength: faster settling time, reduced negative peak overshoot & zero frequency error was attained Limitation: RSO has a high tendency to be trapped in local optima	LFC
[51], 2025	Metaheuristic optimization using GWO	Controller type: PID regulator Optimization method (OP): GWO	One area power system	None	ITAE	Strength: the flexibility and simplicity of the GWO algorithm Limitation: performance of the method was tested for just a one-area system and not more	LFC
[52], 2025	Hybrid intelligent control	Controller type: 2-level neuro-fuzzy PIDF regulator Optimization method (OP): GWO	Three-region interlinked power system	Wind energy	Tie-line power deviation, frequency deviation	Strength: utilization of a hybrid strategy for attaining AGC Limitation: the complex nature of the tuning linked with the method	AGC for power systems integrated with RESS
[54], 2025	Maiden hybrid control	Controller type: $PD^\mu F^\lambda$ (P-Fractional [F] DFF) & MOA based 1 + PIID (PI double ID) regulator Optimization method (OP): Mother Optimization Algorithm (MOA)	Two-region interlinked power system	Solar PV	Tie-line power deviation, frequency deviation, ITSE	Strength: enhanced performance was attained – faster response time, frequency stabilization Limitation: there are so many variables to tune	AGC for complex power grids
[55], 2025	Metaheuristic optimization using Coatis Optimization Algorithm (COA)	Controller type: Tilted ID regulator + first-order filter influence (TID + IDN) Optimization method (OP): COA	Three-region interlinked power system	Solar PV & geothermal energy	Tie-line power deviation, frequency deviation, ITSE	Strength: effective reduction of under/peak overshoot was attained Limitation: method has high computational intensity	AGC for deregulated power systems

V. Conclusion

Investigation shows that there are lots of published works on AGC aimed at addressing the perennial issue that have continued to plague interconnected power networks especially with the integration of RESs in these networks. And this problem is further exacerbated with the increasing sophistication of power networks across different regions of the world arising as a result of continuous advancement in science and technology, smart grid technologies as well as variation in load patterns. Thus, this study has shown that AGC using conventional and intelligent techniques or a combination of both with even newer strategies, the problems prevalent in interlinked networks can be significantly addressed. These strategies however helpful, have their unique limitations. This is because some can be applicable in certain domains and not useful in others given their unique characteristics. As the electricity system becomes increasingly complex, new and adaptable AGC strategies will be needed as well.

Conflict of Interest

The authors declare no conflict of interest in the publication process of this review article.

Author Contributions

G. N. Obiora: Conceptualization, investigation, writing – original draft, review and editing; O. P. Adetunji: review and editing.

References

- [1] I. Pan and S. Das, "Fractional-order load-frequency control of interconnected power systems using chaotic multi-objective optimization," *Applied Soft Computing*, vol. 29, pp. 328-344, 2015.
- [2] M. Shouran, "Load frequency control for multi-area interconnected power system using artificial intelligent controllers," Ph.D Thesis, Wolfson Centre for Magnetism, School of Engineering, Cardiff University, 2022.
- [3] K. Ullah, A. Basit, Z. Ullah, S. Aslam, and H. Herodotou, "Automatic generation control strategies in conventional and modern power systems: A comprehensive overview," *Energies*, vol. 14, no. 9, p. 2376, 2021.
- [4] R. K. Sahu, T. S. Gorripotu, and S. Panda, "Automatic generation control of multi-area power systems with diverse energy sources using Teaching Learning Based Optimization algorithm," *Engineering Science and Technology, an International Journal*, vol. 19, no. 1, pp. 113-134, 2016.
- [5] S. B. Othman and S. K. Ramdas, "Robust Fuzzy-PID technique for the automatic generation control of interconnected power system with integrated renewable energy sources," *European Journal of Electrical Engineering and Computer Science*, vol. 18, no. 4, 2024.
- [6] M. Magzoub and T. Alquthami, "Optimal design of automatic generation control based on simulated annealing in interconnected two-area power system using hybrid PID-Fuzzy control," *Energies*, vol. 15, no. 4, p. 1540, 2022.
- [7] M. M. Mohammad, M. A. Gana, J. Usman, and I. Mustapha, "Review on load frequency control techniques," *Nigerian Journal of Engineering Science and Technology Research*, vol. 19, no. 1, pp. 38-48, 2023.
- [8] B. Peng, X. Ma, X. Ma, C. Tian, and Y. Sun, "Coordinated AGC control strategy for an interconnected multi-source power system based on distributed model predictive control algorithm," *Frontiers in Energy Research*, vol. 10, pp. 1-19, 2023.
- [9] M. M. Gulzar, D. Sibtain, M. Alqahtani, F. Alismail, and M. Khalid, "Load frequency control progress: A comprehensive review on recent development and challenges of modern power systems," *Energy Strategy Reviews*, vol. 57, p. 101604, 2025.
- [10] N. M. Tandel and A. T. Patel, "Load frequency control for 3 area interconnected power systems," *International Journal of Advanced Research in Computer and Communication Engineering*, vol. 6, no. 2, pp. 83-85, 2017.
- [11] R. Khezri, A. Oshnoei, A. Yazdani, and A. Mahmoudi, "Intelligent coordinators for automatic voltage regulator and power system stabiliser in a multi-machine power system," *IET Generation, Transmission & Distribution*, vol. 14, no. 23, pp. 5480-5490, 2020.
- [12] U. I. Isemin and A. J. Onah, "Load frequency control using classical controllers," *Arid Zone Journal of Engineering, Technology & Environment*, vol. 18, no. 2, pp. 231-242, 2022.
- [13] D. D. Rasolomampionona, M. Polecki, K. Zagrajek, W. Wroblewski, and M. Januszewski, "A comprehensive review of load frequency control technologies," *Energies*, vol. 17, no. 12, p. 2915, 2024.
- [14] I. A. Ezenugu and C. S. Nwokonko, "Automatic voltage regulator control system for synchronous generator," *Saudi Journal of Engineering and Technology*, pp. 265-273, 2024.
- [15] A. Surendhar, "LFC and AVR based multi area power system using intelligent techniques," *International Journal of Advanced Research in Basic Engineering Sciences and Technology*, vol. 4, no.5, pp. 344-348, 2018.
- [16] D. Izci, R. M. Rizk-Allah, V. Snasel, S. Ekinci, F. A. Hashim, and L. Abualigah, "A novel control scheme for automatic voltage regulator using novel modified artificial rabbits optimizer," *e-Prime - Advances in Electrical Engineering, Electronics and Energy*, vol. 6, p. 100325, 2023.
- [17] L. H. Lam, L. K. Nam, N. K. T. Dung and N. H. Hieu, "Two-area automatic generation control for power systems with highly renewable energy sources," *Electronics*, vol. 13, no. 15, p. 2907, 2024.
- [18] S. Ekka, "Automatic load frequency control of multi area power systems," M.Eng Dissertation, Department of Electrical Engineering, National Institute of Technology, Rourkela, Deemed University, India, 2014.
- [19] Wikipedia, The Free Encyclopedia, "Electrical Load," Assessed on: May 22, 2025, [Online]. Available: https://en.wikipedia.org/wiki/Electrical_load
- [20] Imdadullah, B. Alamri, A. Hossain, and M. S. J. Asghar, "Electric Power Network Interconnection: A review on current status, future prospects and research direction," *Electronics*, vol. 10, no. 17, p. 2179, 2021.
- [21] M. Ayalew and D. Gebregziabher, "Mitigating the effects of PEV fast charging on grids with renewable and storage systems," in *Active Electrical Distribution Network: Issues, Solution Techniques, and Applications*, 2022, pp. 145-162.
- [22] K. Alzaareer, A. Q. Al-Shetwi, C. Z. El-bayeh, and M. B. Taha, "Automatic generation control of multi-area interconnected power systems using ANN Controller," *Revue d'Intelligence Artificielle*, vol. 34, no. 1, pp. 1-10, 2020.
- [23] Z. Hu, S. Liu, L. Yang, and L. Wu, "Distributed fuzzy filtering for load frequency control of non-linear interconnected power systems under cyber-physical attacks," *IET Control Theory and Applications*, vol. 14, no. 4, pp. 527-538, 2020.
- [24] J. Pasion, "Classical Control techniques," Assessed on: May 23, 2025, [Online]. Available: <https://www.scribd.com/document/840002607/Classical-Control-Techniques>

- [25] J. E. Abban and B. S. Ram, "Application of classical conventional PI and PID controllers and smart fuzzy logic controller for load frequency and tie-line power control in multigeneration power system," *Proceedings on Engineering Sciences*, vol. 3, no. 3, pp. 293-302, 2021.
- [26] A. Zilouchian and M. Jamshidi, "Intelligent control systems using soft computing methodologies," CRC Press LLC, USA, 2001, pp. 26-27.
- [27] Z. Hu, H. Liao, K. Lu, and E. K. Zavadskas, "Soft computing techniques and their applications in intelligent industrial control systems: A survey," *International Journal of Computers Communications & Control*, vol. 16, no. 1, 2021.
- [28] P. Das, S. P. Biswas, S. Mondal, and R. Islam, "Frequency fluctuation mitigation in a single-area power system using LQR-based proportional damping compensator," *Energies*, vol. 16, no. 12, p. 4804, 2023.
- [29] N. Shaik and B. Shimray, "Load frequency control in three-area interconnected power system using PID tuning based on artificial bee colony optimization," in *Energy and Exergy for Sustainable and Clean Environment*, vol. 2, Green Energy and Technology. Springer, Singapore, 2023, pp. 181-196.
- [30] S. S. Aung and Z. M. Htike, "modeling and simulation of load frequency control for three area power system using Proportional Integral Derivative (PID) controller," *American Scientific Research Journal for Engineering, Technology, and Sciences*, vol. 26, no. 2, pp. 301-315, 2016.
- [31] M. Safari, F. Babaei, and M. Farrokhifar, "A load frequency control using a PSO-based ANN for micro-grids in the presence of electric vehicles," *International Journal of Ambient Energy*, vol. 42, no. 6, pp. 688-700, 2019.
- [32] K. Ramireddy, Y. Mudgal, and Y. V. P. Kumar, "Control of frequency deviation in two-area interconnected power system using artificial neural network-based PI controller," *Proceedings of Soft Computing for Problem Solving 2020*, vol. 1392, Singapore, 2021, pp. 539-553.
- [33] A. Demiroren, N. S. Sengor, and H. L. Zeynelgil, "Automatic generation control by using ANN technique," *Electric Power Components and Systems*, vol. 29, no. 10, pp. 883-896, 2001.
- [34] D. Qian, S. Tong, H. Liu, and X. Liu, "Load frequency control by neural-network-based integral sliding mode for nonlinear power systems with wind turbines," *Neurocomputing*, vol. 173, part 3, pp. 875-885, 2016.
- [35] S. Prasad and M. R. Ansari, "Frequency regulation using neural network observer based controller in power system," *Control Engineering Practice*, vol. 102, p. 104571, 2020.
- [36] M. T. Yunis and M. Djemel, "Advanced neural network-based load frequency regulation in two-area power systems," *Iraqi Journal for Electrical and Electronic Engineering*, pp. 145-155, 2024.
- [37] P. A. Gbadega and Y. Sun, "Multi-area automatic generation control of a renewable energy-based hybrid power systems using JAYA optimized model predictive control," *The 3rd International Conference on Power and Electrical Engineering*, Singapore, 2022, pp. 29-31.
- [38] N. A. Orka, S. S. Muhaimin, N. S. Shahi, and A. Ahmed, "An enhanced gradient based optimized controller for load frequency control of a two area automatic generation control system," in *Engineering Applications of Modern Metaheuristics*, vol. 1069, T. Akan, A. M. Anter, A. S. Etaner-Uyar, D. Oliva (Eds). Studies in Computational Intelligence. Springer, Cham, 2023.
- [39] L. C. Saikia, A. Chowdhury, N. Shukya, S. Shukla, and P. K. Soni, "AGC of a multi area gas-thermal system using firefly optimized IDF controller," *2013 Annual IEEE India Conference*, Mumbai, India, 2014.
- [40] T. Ashfaq, S. Mumtaz, S. Ahmad, B. Ullah, and F. R. Albogamy, "Automatic generation control in renewables-integrated multi-area power systems: A comparative control analysis," *Sustainability*, vol. 16, no. 13, p. 5735, 2024.
- [41] S. M. Abd-Elazim and E. S. Ali, "Firefly algorithm-based load frequency controller design of a two area system composing of PV grid and thermal generator," *Electrical Engineering*, vol. 100, no. 1, pp. 1253-1262, 2018.
- [42] M. Mokhtar, M. I. Marei, M. A. Sameh, and M. A. Attia, "An adaptive load frequency control for power systems with renewable energy sources," *Energies*, vol. 15, no. 2, p. 573, 2022.
- [43] K. Kumar, M. Das, and A. K. Karn, "ANFIS robust control application and analysis for load frequency control with nonlinearity," *Journal of Electrical Systems and Information Technology*, vol. 11, no. 65, 2024.
- [44] Z. Farooq, A. Rahman, and S. A. lone, "Load frequency control of multi-source electrical power system integrated with solar-thermal and electric vehicle," *International Transactions on Electrical Energy Systems*, vol. 31, no. 3, pp. 1-20, 2021.
- [45] P. C. Pradhan, R. K. Sahu, and S. Panda, "Firefly algorithm optimized fuzzy PID controller for AGC of multi-area multi-source power systems with UPFC and SMES," *Engineering Science and Technology, an International Journal*, vol. 19, pp. 338-354, 2016.
- [46] Y. Arya and N. Kumar, "AGC of a multi-area multi-source hydrothermal power system interconnected via AC/DC parallel links under deregulated environment," *International Journal of Electrical Power & Energy Systems*, vol. 75, pp. 127-138, 2016.
- [47] G. T. C. Sekhar, R. K. Sahu, A. K. Baliarsingh, and S. Panda, "Load frequency control of power system under deregulated environment using optimal firefly algorithm," *International Journal of Electrical Power & Energy Systems*, vol. 74, pp. 195-211, 2016.
- [48] T. Rathimala and M. Kamarasan, "Application of Firefly algorithm based neural network controller," *International Journal of Innovative Technology and Exploring Engineering*, vol. 8, no. 11, 2019.
- [49] D. K. Gupta, A. K. Soni, A. V. Jha, S. K. Mishra, B. Appasani, A. Srinivasulu, N. Bizon, and P. Thounthong, "Hybrid gravitational-firefly algorithm-based load frequency control for hydrothermal two-area system," *Mathematics*, vol. 9, no. 7, p. 712, 2021.
- [50] A. Khodabakhshian and R. Hooshmand, "A new PID controller design for automatic generation control of hydro power systems," *International Journal of Electrical Power & Energy Systems*, vol. 32, no. 5, pp. 375-382, 2010.
- [51] P. Jangid, V. Nagar, A. Sharma, S. Nagar, and D. K. Palwalia, "Design a PID controller based on grey wolf optimization algorithm for single-area load frequency control," *Journal of Emerging Science and Engineering*, vol. 3, no. 1, 2025.
- [52] G. M. Meseret, R. Kumhar, T. K. Mahato, P. Lakra, B. Kumari, and N. Kumar, "Design of novel secondary controller for agc in multi-area multi-sources power system incorporated renewable energy using a gray wolf optimizer algorithm," *Engineering Reports*, vol. 7, no. 3, 2025.
- [53] P. Gopi, N. C. Alluraiah, P. H. Kumar, M. Bajaj, V. Blazek, and L. Prokop, "Improving load frequency controller tuning with rat swarm optimization and porpoising feature detection for enhanced power system stability," *Scientific Reports*, vol. 14, no. 15209, 2024.
- [54] K. M. AboRas, A. M. Sedik, and M. R. Hammad, "Hybrid dual-area power grid frequency fluctuation effective control utilizing a maiden combination of MOA-based 1+PIID and PD^F controllers," *Science Progress*, vol. 108, no. 1, 2025.
- [55] G. Dei, D. K. Gupta, B. K. Sahu, M. Bajaj, V. Blazek, and L. Prokop, "A novel TID + IDN controller tuned with coatis optimization algorithm under deregulated hybrid power system," *Scientific Reports*, vol. 15, no. 4838, 2025.