

Implementation of a Decoupled Model Reference Adaptive Control (MRAC) of a Flotation Process

M. T. Samodien¹, N. Tshemese-Mvandaba¹, and M. E. S. Mnguni¹

¹Department of Electrical, Electronics and Computer Engineering, Faculty of Engineering and the build Environment, Cape Peninsula University of Technology, Cape Town, South Africa

*Corresponding author's email: 211283983@mycput.ac.za

Abstract – *The approach of applying the Massachusetts Institute of Technology, MIT rule as a decoupled Model Reference Adaptive Controller (MRAC) for a column flotation process is taken up in this article. The airflow rate and wash water flow rate can be adequately regulated with this control scheme. The air holdup and froth depth in the collection zone are used to determine the process performance. Furthermore, a Beckhoff PLC is utilized to evaluate the decoupled MRAC controller. Determining the performance requirements for the implemented controller based on the design simulations is the aim of this evaluation. Unlike the simulated results, the implemented MRAC controller exhibits stability depending on the magnitude of the set point change. This is evident in both the gas holdup and froth height responses. This study indicates the ability of the MRAC controller to be improved by tailoring the reference model accordingly. Improvements such as Overshoot, Peak, and Rise Time can be seen when comparing the response characteristics of Tables II and IV. However, there is not much improvement when it comes to the system's Settling Time.*

Keywords: *Decoupled flotation control, Hardware-in-the-Loop, MIT Rule, Model Reference Adaptive Control, Real-time implementation*

Article History

Received 6 August 2024

Received in revised form 13 September 2024

Accepted 3 October 2024

I. Introduction

Froth flotation separation is a widely used technique for separating minerals and is applied across various industries. One of the main sectors that extensively relies on froth flotation is the mining industry, contributing approximately 200 billion Rand annually to South Africa's Gross Domestic Product (GDP) [1]. Nevertheless, the potential of the flotation process is rooted in the ability to automate control. The lack of automated process performance has often led to unsuccessful control in many instances. This includes the use of traditional PID and fuzzy logic controllers. These traditional controllers are regarded as challenging to tune due to the complexity of the flotation process. The development of an advanced controller incorporating Real-Time optimization could potentially enhance both economic efficiency and process performance.

An adaptive control system automatically compensates for changes in system dynamics by adjusting the controller characteristics so that the overall system performance remains the same, or relatively maintained at an optimum level. This control system considers any degradation in plant performance with time. The benefit of using Model Reference Adaptive Control (MRAC) is

that it provides quick adaptations for the defined inputs. Therefore, model-reference controllers are added, due to their adaptation mechanism. MRAC theory is designed to adjust the controller parameters in a way that the actual plant output would track the output of a reference model using the same respective inputs, [2], [3].

This paper will make use of the pilot flotation column that was discussed in the Nasser et al. (2020) research paper, [4]. Two peristaltic pumps and rotary encoders were used in this flotation column to monitor and regulate the feed and tailings flow rates. A diaphragm pump was used to control the wash water. A compressor provides the air, and a stepper motor and an airflow meter regulate the airflow. The pulp level in the column is determined by an ultrasonic sensor, and two pressure sensors—P1 and P2 in Fig. 1 below—are used to measure the pulp.

To derive the dynamic model of the system a research article published in [4] employed a methodology akin to that of Maldonado et al. (2009), [5]. Through the manipulation of the input variables (wash water, air flow, and tailings flow rate), the step responses of the three secondary variables were obtained. Throughout the process, the feed flow rate is taken into consideration as a constant. The system is decoupled using the "simplified decoupled system" defined in [6]

This is an Open Access article distributed under the terms of the Creative Commons Attribution-Noncommercial 3.0 Unported License, permitting copy and redistribution of the material and adaptation for commercial and uncommercial use.

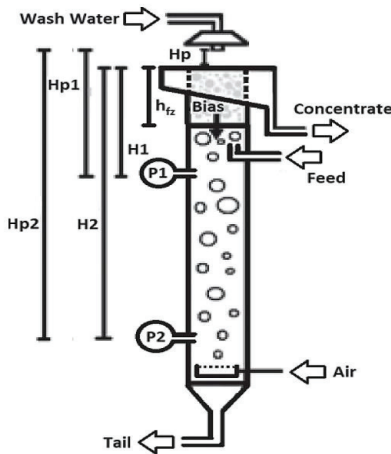

Fig. 1. Pilot Flotation Column, [3]

A Model Reference Adaptive Controller is designed as an advanced controller. The objective of this article is to develop the adaptive controller and to analyze its performance based on predetermined test conditions. A brief explanation of the functionality of the adaptive controller is given. With the flotation system still decoupled, the model reference adaptive controller is developed. The MRAC controller is then simulated using MATLAB/Simulink and the results are analyzed based on the given criteria.

The article can be divided into four parts, starting with an introduction in section one. Section Two covers the Model Reference Adaptive Control and provides a concise explanation of the MRAC theory utilizing the MIT rule. This section also outlines the design procedure for the MRAC controller for the flotation process. The third section presents the test outcomes of both the simulated and implemented systems. Finally, the fourth section offers conclusions based on the study conducted in this article.

II. Model Reference Adaptive Control

A. Overview of Model Reference Adaptive Control

The MRAC design consists of a reference model, controller, and adjustment mechanism. The reference model is used to obtain the desired response. The controller or control law parameter θ is described as a collection of adjustable parameters, but mainly dependent on the adaptation gain (γ). The adjustment mechanism alters the controller parameters to track the response of the reference model. For this design, we will be using the

Massachusetts Institute of Technology (MIT) rule presented in [2] as the controller adjustment mechanism seen in Fig. 2.

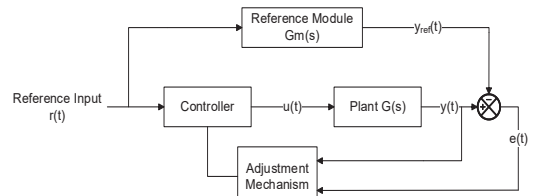

Fig. 2. MRAC system, [7]

B. Reference Model $G_m(s)$

The importance of the reference model is to attain the desired response characteristics of a given input. Every control loop in the decoupled system will have a reference model in it. To acquire the desired response, a second-order system is employed. For this study, it is assumed that the plant parameters are unknown. These are general presumptions that should be made when creating a reference model. A second-order characteristic equation is used to determine the desired closed-loop poles.

$$G(s) = \frac{\omega_n^2}{s^2 + 2\zeta\omega_n s + \omega_n^2} \quad (1)$$

For this study, a Percentage overshoot of 10% and a settling time of 500 sec was used to fulfil the desired characteristics. These parameters were considered reasonable based on the plant's system dynamics. The damping ratio ζ and un-damped natural frequency ω_n were determined to be 0.5912 and 0.0135 respectively with the use of Equations 2 and 3.

$$\zeta = \frac{\sqrt{\ln\left(\frac{\%OS}{100}\right)^2}}{\sqrt{\pi^2 + \ln\left(\frac{\%OS}{100}\right)^2}} \quad (2)$$

$$\omega_n \approx \frac{4}{\zeta t_s} \quad (3)$$

The resultant Reference model characteristics are given in Equation 4.

$$G_m(s) = \frac{0.0001831}{s^2 + 0.016s + 0.0001831} \quad (4)$$

C. Adaptation Rule

The MIT rule, also referred to as the sensitivity model, is an adaptation rule that is obtained by choosing a quadratic performance criterion that minimizes the set point tracking error across a particular time frame. The

following integral, which is also referred to as the cost function, can be used to define the criteria, [8].

$$J(t+T) = \frac{1}{2} \int_t^{t+T} e^2(\tau; \theta) d\tau \quad (5)$$

For which the set point tracking error is defined by the difference between the Plant Model $x_p(t)$ and Reference model $x_m(t)$ as seen in equation 4.

$$e(t; \theta) = x_p(t) - x_m(t) \quad (6)$$

With θ_i being the unidentified parameters of $x_p(t)$ and $x_m(t)$ over the tracking error period T . Based on equation 3, these parameters are updated as follows:

$$\theta(t+T) = \theta(t) - \gamma \int_t^{t+T} e(\tau; \theta) \frac{\partial e(\tau; \theta)}{\partial \theta} d\tau \quad (7)$$

Thus,

$$\frac{\theta(t+T) - \theta(t)}{T} = -\frac{\gamma}{T} \int_t^{t+T} r(\tau; \theta) \frac{\partial x_p(t; \theta)}{\partial \theta} d\tau \quad (8)$$

where

$$\frac{\partial e(\tau; \theta)}{\partial \theta} = \frac{\partial x_p(t; \theta)}{\partial \theta} \quad (9)$$

As $\lim_{T \rightarrow 0}$ the change in parameters is as follows

$$\frac{\partial \theta(t)}{\partial t} = -\gamma \times e(t; \theta) \times \frac{\partial x_p(t; \theta)}{\partial \theta} \quad (10)$$

The term ‘‘sensitivity derivative’’ refers to the sensitivity to variations in the state parameters. This method is sometimes referred to as the MIT rule or the gradient technique in practice. Additionally, it is mentioned that system stability is not always guaranteed by the technique, [8].

D. Decoupled MRAC Design for the Column Flotation Process

The MIT rule is used in Simulink to design the decoupled MRAC controller. The goal is to create a decoupled controller that can track the corresponding reference models for both the gas holdup and the froth height. The error can be defined by the following equation when operating in the s-domain.

$$E(s) = K_T T(s) U(s) - K_m G_m(s) U_c(s) \quad (11)$$

The decoupled flotation process is defined by $T(s)$ and the decoupled flotation process gain is given by K_T . The reference model transfer function $G_m(s)$ and respective gain K_m is coupled with the control law $U_c(s)$.

The control law is defined by

$$u(t) = \theta * u_c(t). \quad (12)$$

To determine the sensitivity derivative, first partial differentiation is applied to the following

$$\frac{\partial E(s)}{\partial \theta} = K_T T(s) U_c(s) = \frac{K_T}{K_m} Y_m(s). \quad (13)$$

Thus, the sensitivity derivative is given as

$$\frac{\partial \theta(t)}{\partial t} = -\gamma e \frac{K_T}{K_m} y_m = -\gamma' e y_m. \quad (14)$$

The parameters of θ can be varied by applying the law stated in Equation 12. The law can be applied to the gas hold-up and foam height decoupled control loops, producing the Simulink model shown in Fig. 3. The reference model transfer functions of the corresponding froth height and gas hold-up are represented by the Reference Model 1 (RM1) and Reference Model 2 (RM2) blocks. Product 2 and Product 6 carry out the implementation of the control law. Gama1 and Gama2, the adaptive gains for this model, are set at +0.005 and -0.005, respectively. These Gama values were determined through trial and error resulting in the optimum step response of the flotation process. Any real value > 0 can be the adaptation gain. The Model Reference Adaptive controller depicted in Fig. 3 was created using equation 12.

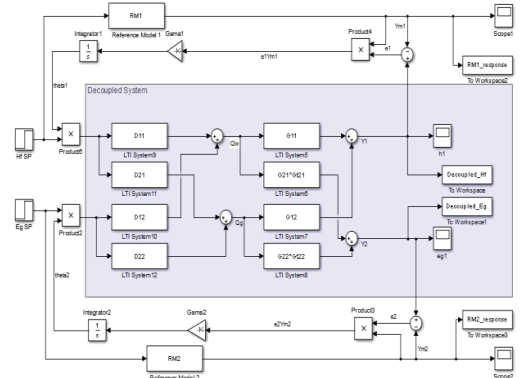

Fig. 3. Simulink Model of Decoupled MRAC of a flotation process

E. Implementation of MRAC design of the decoupled flotation process

The previous section demonstrates the design process for a decoupled MRAC design of a flotation column. A modified SIMULINK model that can support the switch from SIMULINK to TwinCAT 3 is presented in this section; Fig. 4 illustrates this. The model is then installed on a Beckhoff C6015 Programmable Logic Controller

(PLC) for Hardware-In-Loop (HIL) implementation using the TwinCAT 3 environment.

The TwinCAT Measurements Tool TC1300 is used to import the results in order to implement the Beckhoff PLC in real-time. In addition to enabling real-time monitoring, the TwinCAT simulation environment also makes it possible to update and load system variables and blocks onto the PLC. The control loop setpoint values Hf_{SP} and Eg_{SP} , respectively, are updated using this technique.

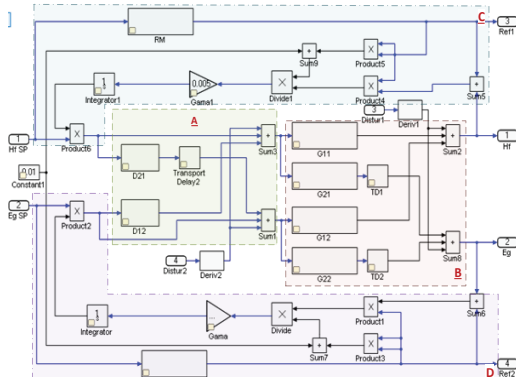

Fig. 4. TwinCAT3 Decoupled MRAC of a Flotation Process

Based on Fig.4, the decoupled flotation process is marked out as A and B, where A is known as the decoupler and B is known as the flotation plant. It can be seen in A that D11 and D22 are replaced with straight connections due to the transfer functions being equal to 1. This reduces the size of the model which is restricted by the Beckhoff automation licensing. The MRAC controller for froth height and gas holdup are in the areas marked out as C and D.

III. Results and Discussion

This section will compare the simulated and implemented test results of the decoupled MRAC flotation controller. Each controller will undergo a particular set point variation. The times at which the simulation set points and the experiment set points may vary. This is due to the limitation of the free version of the Beckhoff real-time scope view license. Thus, the maximum length allowed to record the real-time response was 60 minutes. More information about the simulation and experiments are discussed below.

A. Simulation Test Results

Table I provides the best description of the set point variations that affect the MRAC Simulink model shown in Fig. 2. Four modifications to the set point pulse signal

are simulated in this test scenario. The changes are made from 1,5, 3, and 4 at various times to the air-loop, as the froth height loop is illustrated. Observing MRAC controller performance under various set point changes is the objective. Each set point is changed at different intervals to ensure that the flotation process is successfully decoupled.

TABLE I
SIMULINK SETPOINT CHANGES VS TIME

Hf		Eg	
Setpoint	Time (sec)	Setpoint	Time (sec)
1	0	1	500
5	1000	8	1500
3	2000	5	3000
4	3000	5	4000

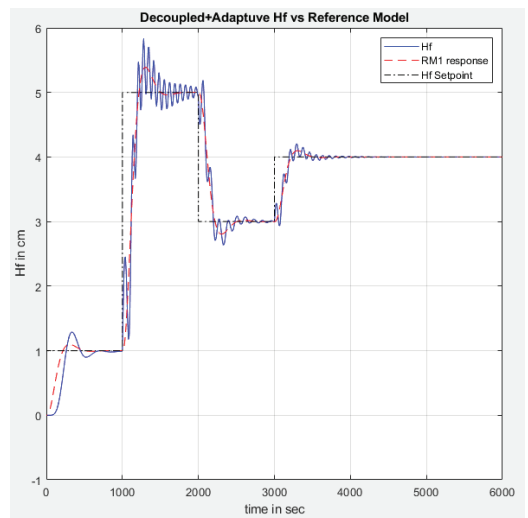

Fig. 5. Froth Height Simulation Set-point Tracking

The simulated froth height response is seen in Fig. 5. The froth height results demonstrate positive response characteristics when subjected to a minor set point variation of 1cm. The set point is then adjusted by a magnitude of 5 at $t = 1000$ sec, causing the response to oscillate along with its respective reference module response. Two more minor set point variations occur at $t = 2000$ sec and $t = 3000$ sec. The froth height response seems to react with more stability as reductions in oscillations are noted and a steady state is achieved.

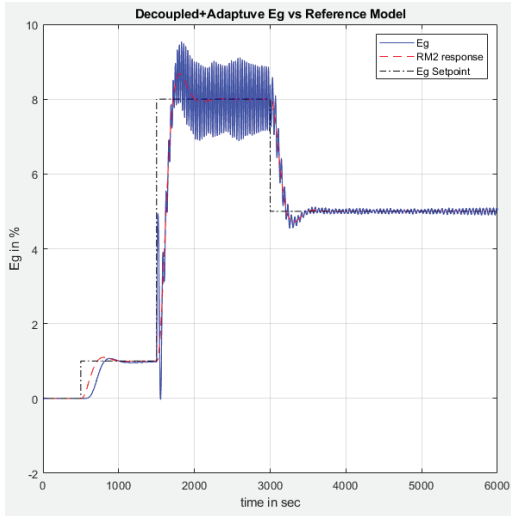

Fig. 6. Gas Holdup Simulation Set-point Tracking

Fig. 6 shows the simulated Gas Holdup response. Positive response characteristics are also evident in the gas holdup results when a minor set point variation of 1% is applied. At $t = 1500$ sec, the set point is then modified by a magnitude of 8, which causes the response to oscillate independently of its corresponding reference module response. At $t = 3000$ seconds, there is a slight change in the set point, going from 8% to 5%. Instead of reaching a steady state, the gas holdup response appears to respond by lessening the oscillations' magnitude.

TABLE II
STEP RESPONSE CHARACTERISTICS OF THE SIMULATED DECOUPLED MRAC FLOTATION SYSTEM

Characteristics	Hf (cm)	RM1	Eg (%)	RM2
RiseTime (sec):	244.646	135.5231	284.9500	135.523
SettlingTime (sec):	523.697	437.8855	500.0000	437.885
SettlingMin:	0.8991	0.9025	0.9057	0.9025
SettlingMax:	0.99	1.1000	1.0521	1.1000
Overshoot (%):	29.1733	10.0000	6.7557	10.0000
Peak:	1.292	1.1000	1.0674	1.1000
PeakTime (sec):	328.378	287.8231	361.1478	287.823
ess	0.001	0	0.001	0

B. Experiment Test Results

The MRAC TwinCAT model of a flotation process in Fig. 4 is then subject to several set point variations best described in table III. This is to monitor the MRAC controller's set point tracking performance. The real-time simulation only allows the variables to be recorded for a duration of 60 min. Thus, the recordings will need to be

restarted after each set point change will occur every 15 min. The time in table III now represents the time at which the set point occurs in each test run.

TABLE III
EXPERIMENT SETPOINT CHANGES VS TIME

Hf		Eg	
Setpoint	Time (min)	Setpoint	Time (min)
1	0	1	0
5	15	8	15
3	30	5	30
4	45	5	45

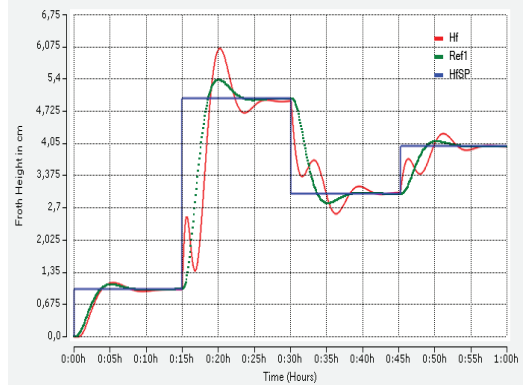

Fig. 7. Real-time simulation results of Froth Height with respect to time

It can be seen from Fig.7, that the Model Reference Adaptive controller when implemented onto the Beckhoff PLC responds positively to minor set point variations, as a step input with a magnitude of 1 is introduced into the system at $t = 0$ min. It is also noted that there is a delay from when the step input occurs and to when the system begins to respond. The overshoot and time delay of the froth height seen intends to match the simulated responses of the Simulink model seen in Fig.5. However, oscillations in the Froth height do occur as the response transitions between set points, for example, at $t = 0:15H$; $t = 0:30H$ and $t = 0:45H$. This could be caused by the calibration of the rise time of the reference model being too slow and the controller attempting to adjust the response to duplicate the reference model.

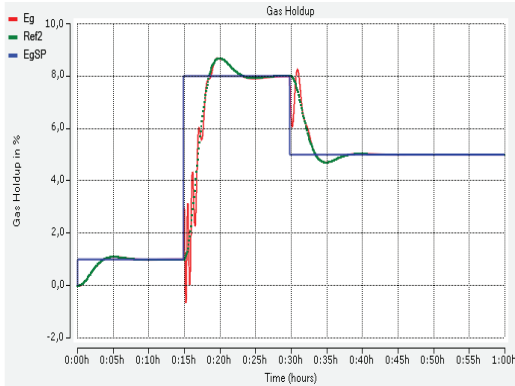

Fig. 8. Real-time simulation results of Gas Holdup with respect to time

In Fig.8 the Model Reference Adaptive controller when implemented onto the Beckhoff PLC responds positively to minor set point variations however, as a step input from a magnitude of 1% to 8% to the gas holdup is introduced into the system at $t = 0:15H$. It is also noted that there is a delay from when the step input occurs and to when the system begins to respond. A slight oscillation occurs just after the set point is changed. However, the response does seem to stabilize but does not reach a steady state before the next set-point change. The overshoot and time delay of the gas holdup seen in Fig. 8 do tend to match the simulated responses of the Simulink model seen in Fig. 6, aside from the oscillations that occur when the set point is reached in Fig. 5. However, oscillations in the gas holdup does occur as the response transitions between set points, as seen at $t = 0:15H$; $t = 0:30H$ and $t = 0:45H$. This could be caused by the calibration of the rise time of the reference model being too slow and the controller attempting to adjust the response to duplicate the reference model.

TABLE IV
STEP RESPONSE CHARACTERISTICS OF THE IMPLEMENTED DECOUPLED MRAC FLOTATION SYSTEM

Characteristics	Hf (cm)	RM1	Eg (%)	RM2
RiseTime (min):	3:10	2:52.7	4:18	2:52.7
SettlingTime (min):	11:29	9:55	16:37	9:55
SettlingMin:	0.98	0.9025	0.98	0.9025
SettlingMax:	0.99	1.1000	0.99	1.1000
Overshoot (%):	13	9.75	4.5	9.75
Peak:	1.13	1.097	1.04	1.097
PeakTime (min):	5:07	4:57.4	6.23	4:57.4
ess	0.001	0	0.001	0

C. Discussion

It can be seen from Fig. 4 and Fig. 5 that the Simulated Model Reference Adaptive controller responds positively

to minor set point variations. The implemented design indicates a resemblance to the simulated response as seen in Fig. 7 and Fig. 8. The larger set point changes do differ between the simulation and the implemented design. It can be seen in both simulation figures (Fig. 4 and Fig. 5) that both the froth height and gas holdup responses undergo oscillations. However, the implemented design results indicate an improvement in stability and reduced oscillations along their respective reference model response. When comparing the response characteristics of Tables II and IV. Improvements such as Overshoot, Peak, and Rise Time can be seen. Although it comes at the expense of the Settling time being much longer.

However, despite the set point tracking still being evident, set point variations at a larger magnitude will result in instability and oscillations. This can be fixed by reducing the gamma value for the Adaptive controller. However, with a reduction in gamma the set point error tracking will be less aggressive resulting in an overdamped response. The steady-state error will increase for small set-point variations, but the MRAC controller response will maintain stability under larger set-point variations.

IV. Conclusion

The successful application of an adaptive controller that applies the MIT rule to a column flotation process is the conclusion of this study. To accomplish this, the Simulink model must be moved to the TwinCAT 3.1 environment to implement the controller. Set point variations are applied to the implemented adaptive controller to track its set point tracking capabilities. As might be expected from an adaptive controller, the implemented controller performed remarkably well, but the outcomes indicate some space for development. This study indicates the ability of the MRAC controller to be improved by tailoring the reference model accordingly.

V. Acknowledgment

This work was supported by the THRIP/NRF project, “Centre for Real-Time Distributed Systems (CRTDS).

VI. Conflict of Interest

The authors declare no conflict of interest in the publication process of the research article.

VII. Author Contributions

The research work was conducted and analyzed by Moegamat Tashreeq Samodien; Nomzamo Tshemese-Mvandaba, reviewed, corrected, and edited the paper, and

Mkhululi Mnguni reviewed and edited the paper; all authors approved the final version.

VIII. References

- [1] G. Saifadin, "statista," 13 September 2020. [Online]. Available: <https://www.statista.com/statistics/1121214/mining-sectors-value-added-to-gdp-in-south-africa/#statisticContainer>. [Accessed 20 June 2021].
- [2] G. Feng and R. Lozano, *Adaptive Control Systems*, Oxford: Elsevier Science, 1999.
- [3] S. Nasser, M. R. Khaledi, A. Ramezani, M. Abdollahi and M. Mohseni, "An Adaptive Decoupling Control Design for Flotation Column: A Comparative Study Against Model Predictive Control," *IETE J Res*, vol. 0, no. 0, p. 1–14, 2020.
- [4] M. Maldonado, A. Desbiens and R. del Villar, "Potential use of model predictive control for optimizing the column flotation process," *Int J Miner Process*, vol. 93, no. 1, pp. 26–33, 2009.
- [5] L. Liu, S. Tian, D. Xue, T. Zhang, Y. Chen and S. Zhang, "A Review of Industrial MIMO Decoupling Control," *Int. J. Control Autom. Syst.*, vol. 17, no. 2019, pp. 1246–1254, 2019.
- [6] P. Jain and N. M.J., "Design of a Model Reference Adaptive Controller Using Modified MIT Rule for a Second Order System," *Advance in Electronic and Electric Engineering*, vol. 3, no. 4, pp. 477–484, 2013.
- [7] J. Candy, "Model Reference Adaptive Control (MRAC) for Additive Manufacturing (AM)," Lawrence Livermore National Lab, Livermore, 2021.
- [8] Beckhoff Automation, "Beckhoff Information System," 18 August 2023. [Online]. Available: <https://www.beckhoff.com/en-gb/>. [Accessed 15 January 2024].
- [9] J. D. le Roux and I. K. Craig, "State controllability of froth flotation cell," *International Federation of Automatic Control*, Pretoria, 2019.
- [10] F. Maurice, G. j. Jamson and R. H. Yoon, *Froth Flotation*, Littleton, Colo. : Society for Mining, Metallurgy, and Exploration, 2007, pp. 4–891.
- [11] P. Quintanilla, S. J. Neethling and P. R. Brito-Parada, "Modelling for froth flotation control: A review," *Minerals Engineering*, vol. 162, no. 0892–6875, pp. 1–19, 2021.
- [12] N. Tshemese, R. Tzoneva and S. Mnguni, "Decentralised PI controller design based on dynamic interaction decoupling in the closed-loop behaviour of a flotation process," *International Journal of Electrical and Computer Engineering (IJECE)*, vol. 11, no. 6, p. 4865, 2021.
- [13] N. Tshemese-Mvandaba, M. E. S. Mnguni. 2023. Decentralized proportional-integral controller based on dynamic decoupling technique using Beckhoff TwinCAT-3.1. *International Journal of Electrical and Computer Engineering (IJECE)*, vol. 13, no. 3, pp. 2721–2733, 2023. ISSN: 2088-8708, DOI: 10.11591/ijece.v13i3.pp2721-2733

