

# Design of Wireless Monitoring and Controlling System of Power Transmission Lines

J. Ismail Abdallah<sup>1</sup>, Mortada M. Abdulwahab<sup>2\*</sup>

<sup>1</sup> Al-Gezira Technical College,

<sup>2</sup>Department of Electronic, Faculty of Engineering and Technology, University of Gezira, Sudan

\*corresponding author: murtada@uofg.edu.sd

---

**Abstract** – In the traditional overhead power transmission lines systems, the detection of the faults in the electric lines is difficult and may lead to comparatively longer time to repair them. Specifically, the faults resulting from loads or current leakage are difficult to detect. This paper presents a monitoring system to detect such faults. The weather conditions such as humidity, temperature, and rainfall, as well as the current flow of the line are monitored to detect the faults and highlighted the specified fault region. The system disconnects the power when an over value exists. The design consists of a group of nodes, each one contains a transmitter and receiver unit. The transmitter consists of a group of sensors namely DHT11 sensor, rain sensor and ACS755 which sends the measured information as frames via Xbee technology. All these nodes send their data to the main node. Virtual Serial Port Emulator VSPE used to access multiple nodes on the main pc. The result in this paper shows the performance of the system when all the parameters were within the allowed range. The design also was simulated in different out of range values for over current, high humidity and high rainfall. The obtained results were accurate and prove that it works successfully.

**Keywords:** Electric line; Sensors; Wireless control; Xbee

## Article History

Received 11 September 2019

Received in revised form 22 November 2019

Accepted 24 December 2019

---

## I. Introduction

Power transmission lines basically used to enable transferring electric energy from the generating source to the distributing systems [1]. The distribution system refers to the unit which is responsible to connect the distribution substations to the customers service [2]. Monitoring circuit of the transmission lines is required due to the long-distance of transmission between any two substations [3]. In the traditional overhead power transmission lines systems, the maintenance service is expensive due to the wasted time in detecting the region of faults. Moreover, it does not have fast protection from the bad weather status.

Xbee radio was invented in 2005 [4]. It was designed based on the IEEE standard 802.15.4 which specifies the point to point connection and the star connection [5]. Xbee was introduced with two versions: the lower power 1mW Xbee which is low cost and the higher power version 100mW Xbee. Since then, several versions of Xbee radio were improved [6].

2.4GHz Xbee module became very popular because it offers reliable and simple communication between any two electronic devices such as microcontrollers or computers. The communication can be done over the

serial port or point to point connection [7]. The applications of these modules in the connection between devices increased because it reduced the use of cables [8].

This paper aimed to provide a monitoring system for the electric transmission lines using Xbee. Therefore, several parameters were selected to be monitored wirelessly using Xbee technology. These parameters were the line current, temperature, humidity and the amount of rainfall. The rest of the paper includes the survey of related works, the design method and the simulation results.

## II. Related Works

Unlike other papers that were reviewed in Table I, this paper presents a significant contribution because it has not only focused on monitoring power, but it also monitored the weather conditions which can affect the transmission line. Also, the system enables the disconnection of the electric line if there were over value measured in any of the parameters.

In previous work, Javid [9] discussed in his paper the advantages of using wireless monitoring and controlling of the power. Abraham [10] in his design

proposed a simple circuit with the use of wireless technology to sense the RMS value of the current in the line, however the work does not contain the monitoring of other parameters. Banupriya [11] used ZigBee wireless technology to monitor the parameters of voltage and current of the transformer during the power transmissions.

Minal [12] presented in his paper a schematic of wireless controller used for electric appliance, but the real design was not presented. Malik [14] proposed a model of monitoring power transmission lines without showing the real design in his paper, albeit the mathematical framework used to illustrate the performance of the model. Sachin [15] presented in his paper a monitoring design using wireless technology in which the system aimed to track the electricity flowing to reduce the electricity theft.

TABLE.1:  
SURVEY OF RELATED WORKS

Author	Year	Description
Abraham[10]	2011	This paper describes a simple method to implement a wireless embedded system to continuously monitor the RMS current through the power line
Javid <i>et.al</i> [9]	2012	This paper describes the user-friendly control home appliances, power on/off through the internet, PDA using Graphical User Interface (GUI) and through GSM cellular mobile phone
Banupriya <i>et.al</i> [11]	2013	This paper proposes a wireless ZigBee technology to monitor the parameters of the transformer
Minal Nikose <i>et.al</i> [12]	2014	This paper presents the design and implementation of a novel wireless sensor network-based home security system with a modular self-reconfigurable remote controller
S. V. Shinde <i>et.al</i> [13]	2014	This paper presents the design and prototype implementation of new Wi-Fi technology-based monitoring and controlling the field equipment or machines using Phone, Tablet Laptop or any desktop pc having Wi-Fi utility with IEEE 802.11b, g and n standards
Malik Ali Judge <i>et.al</i> [14]	2017	This paper presents a three level hybrid model for real-time monitoring of transmission lines

Sachid[15]	2017	Used microcontroller and ZigBee technology to monitor the electricity flowing in smart grid.
------------	------	--

### III. Methodology

The current measurements are reported with a voltage output, the calculation of the measured current by the current sensor can be given by:

$$V_{rms} = \left(\frac{V_{pp}}{2}\right) \times 0.707 \tag{1}$$

where:

$V_{pp}$  is the peak-to-peak voltage.  
 $V_{rms}$  is the root mean square voltage.

The output of the sensor can be calculated by the following equation:

$$\text{Current (amp RMS)} = \frac{V_{rms} \times 1000}{ACS \text{ sensitive}} \tag{2}$$

where:

Current (amp RMS) is the output of the current sensor.  
 ACS sensitive is the sensitivity of ACS sensor (66, 100, 185).

The current circuit is shown in Fig.1. This circuit contains indicators to illustrate the status of flow current in the line.

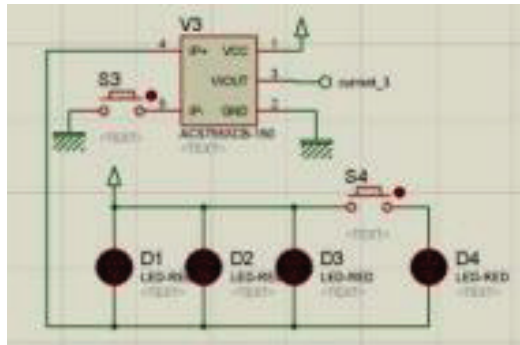

Fig. 1. Current circuit

Humidity calculation can be given by:

$$RH = \left(\frac{P_w}{P_s}\right) \times 100\% \tag{3}$$

where:

$RH$  ≡ relative humidity.  
 $P_w$  ≡ density of water vapor.  
 $P_s$  ≡ density of water vapor in saturation.

A rain sensor is a switching device which usually used to indicate of amount of rainfall rate. The operation of the rain sensor depends on the type of sensor. In this design the operation of the rain sensor has been simulated using potentiometer as shown in Fig.2. Therefore, the simulation used variable input voltage range to acts as reading of rain sensor.

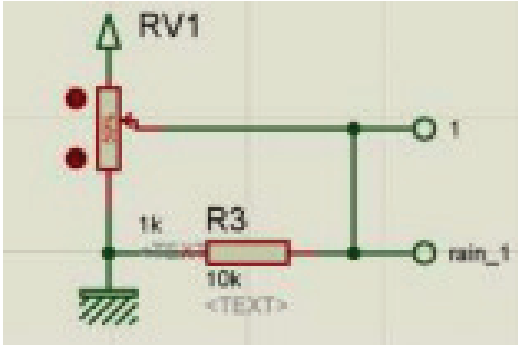

Fig. 2. Rainfall equivalent sensor circuit

The block diagram shown in Fig.3 explains how the system works. The processes start when the master controller sends the frame containing the measured values of each point which sent sequentially by using the Xbee wireless module. Then, the node receiver receives all the responds and displays it in the monitoring unit. Upon receipt of the specific region and according to the reading values of the sensors, the controller may disconnect the line if the reading value of sensor is greater than the saved condition value. Then, the controller in the transmitter side sends this value to the main control unit. The status will consequently be changed as an overvalue case.

The system assumes four nodes in which the configuration of each node is shown in Fig.4 where each node has a transmitter and receiver section. All these nodes send data to the main node which monitors the situation of each node region. The design consists of a controller unit, a group of sensors, a relay unit which acts as a circuit breaker and an Xbee module.

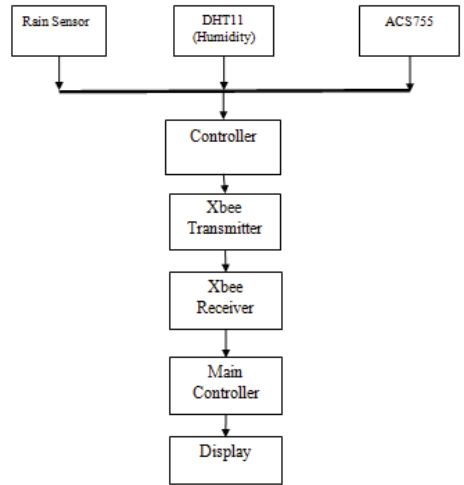

Fig. 3. Block diagram

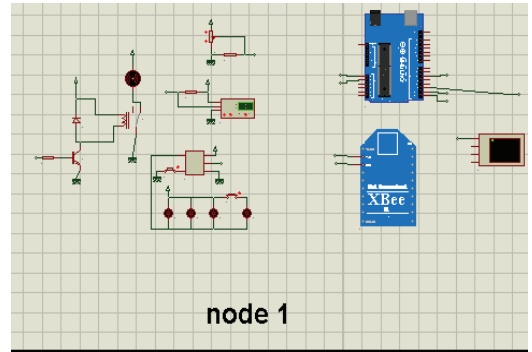

Fig. 4. Node schematic

#### IV. Results and Discussions

The design and the simulation results were carried out using proteus software and VSPE application. The overhead electric transmission line was simulated by using four indicators and two switches to represent the normal situation and the over current situation. The simulation results when there is a normal reading of current in the power transmission line is shown in Fig.5. In this normal case of current the relay remained closed. For simulation purpose the normal current assumed to be equal or less than 136 A.

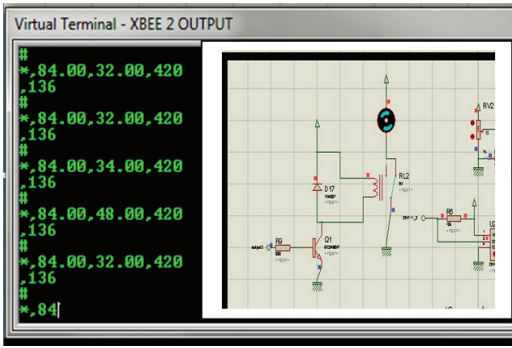

Fig. 5. Normal values

In the normal case the operation of overhead electric transmission line is represented as the equivalent circuit that shown in Fig.6. The normal operation was of the line simulated by turning on three indicators and opening S4.

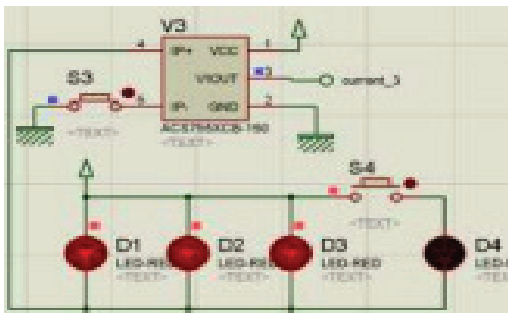

Fig. 6. Line indicators in normal current

When an over current occurred all the indicators were turn on and both switches S4 and S3 were closed as shown in Fig.7.

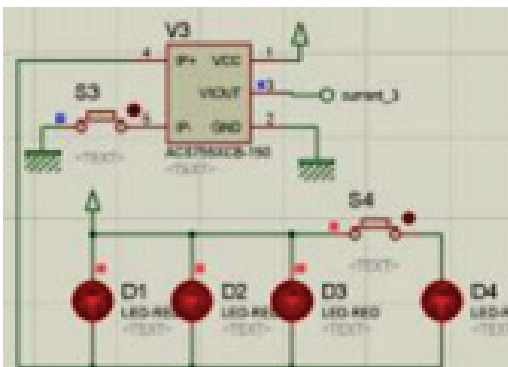

Fig. 7. Over current

As shown in Fig.8 the relay is opened when the value of current exceeded the reference value. The results frame is showing the obtained values in the following order humidity, temperature, rainfall and current.

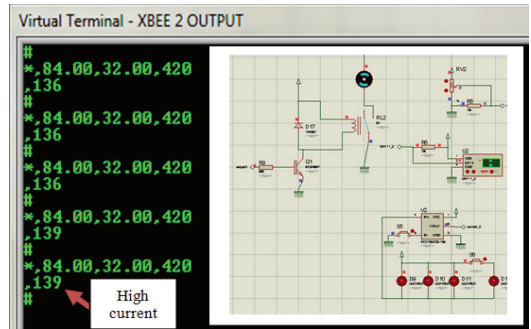

Fig. 8. High current

Similarly, the control unit disconnects the line when there are over values in humidity and rainfall ratio these cases were shown in Fig.9 and Fig.10 respectively.

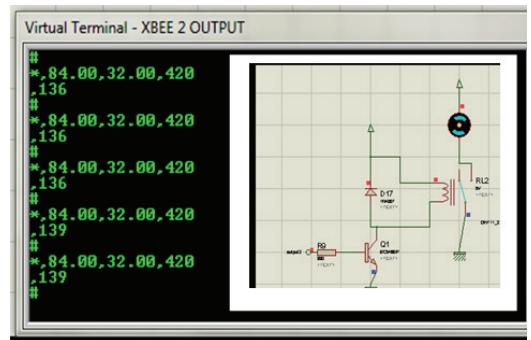

Fig. 9. High humidity

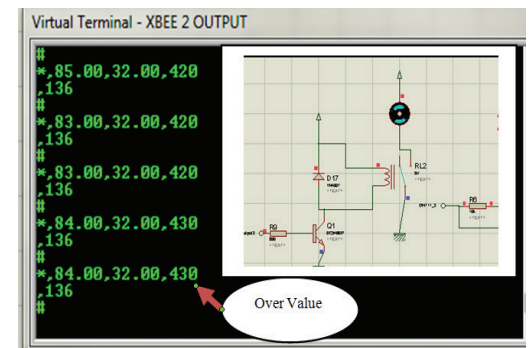

Fig.10. High ratio of rainfall

For the simulation purpose, the saved reference ratio of humidity in the system was selected to be equal or above 84%. The saved reference range of the normal rainfall was assumed to be 430 as an output voltage because the real sensor was simulated by using the potentiometer device. The overall results demonstrates that system achieved the required goals by monitoring the weather parameters and controlled the flow of current according to the condition of weather.

For example, the results showed how the line was disconnected when the system examined the case of over current as shown in Fig.7. This action is important to protect people from electricity shock. In the case when there was a high humidity level above the allowed range (84%) such as in Fig.8, the relay directly disconnected the line.

High rate of rainfall may cause the disconnection of the transmission line. Therefore, when the rainfall exceeded the reference range, the line is disconnected automatically to avoid the risks of cutting of the power line. This case was shown in Fig.8. By simulating the system in the normal ranges of all these parameters, the power line status in this case became connected as shown in Fig.5.

## V. Conclusion

In this system, the data was collected continually from the different regions, it contains important information in an extreme weather conditions such as temperature, humidity and rainfall in addition to the current situation. The simulation results were satisfied and accurate. The system was built based on Xbee technology and simulated using the Proteus environment. For future work, this system can add the parameter of winds speed to be monitored.

## Acknowledgements

This works was under supervised of Al-Gazera Technical College.

## References

- [1] Debapriya Das" Electrical power systems", New age international press,(2016), ISBN: 978-81-224-2515-4.

- [2] Hadi Saadat,( 1999 ),McGraw Hill , ISBN:0-07-561634-3.
- [3] Reed,G.F, Philip .PA, Barchowsky.A, Lippert .CJ,Sparacino.AR"Sample survey of smart grid approaches and technology gap analysis" In innovative smart grid technologies Conference .Europe(IGST Europe)IEEE PES (2010),pp: 1- 10.
- [4] "Archived copy". Archived from the original on March 16, 2012. Retrieved May 11, 2011.
- [5] Online.XBee Transceiver Modul XB24-AWI-001, accessed 1 Sept. 2019, < <https://www.digikey.com/product-detail/en/digi/XB24-AWI-001/XB24-AWI-001-ND/935965>>.
- [6] Online. XBee vs XBee-Pro, accessed 1 Sept. 2019, <[https://www.youtube.com/watch?v=G\\_ScqGDY2eo](https://www.youtube.com/watch?v=G_ScqGDY2eo)>.
- [7] Online. XBee Wire Antenna, accessed 1 Sept 2019, <<https://www.amazon.com/Digi-XBee-1mW-Wire-Antenna/dp/B004G4ZHK4>>.
- [8] John Lnn. Jonas Olssen. 15<sup>th</sup> March 2005. ZigBee for wireless networking..
- [9] N. Javid, A. Sharif, A. Mahmood, S. Ahmed, U. Qasim, Z. A. Khan, Monitoring and Controlling Power using Zigbee Communications,2012, aXiv: Vol.1, PP.2208-2331.
- [10] P. A. Abraham, Dr. K. A. Narayanankutty, Dr. Padmanaban Nambiar. Bonfring International Journal of Power Systems and Integrated Circuits, Special Issue. Wireless Embedded System for Power Line Monitoring. December, 2011.
- [11] M. Banupriya, R. Punitha, B. Vijayalakshmi, C. Ram Kumar." Power Transmission Monitoring System Using Wireless Zigbee Technology, Global Journal Inc. (USA). ISSN: 2249-4596& ISSN: 0975-5861, 2013.
- [12] Minal Nikose. Pratibha Mishra. Avinash Agrawal. "A Review of Industrial automation By ZigBee Based Wireless Remote Controller.", International Journal Of Scientific & Technology Research Volume 3.. April 2014
- [13] Prof. S. V. Shinde, Mr. Pravin Zaware." Wi-Fi based Monitoring and Controlling of Embedded System. ", International Journal of Electronics Communication and Computer Engineering. ISSN: 2249-071X.,July2014.
- [14] Malik Ali Judge, Awais Manzoor, Fahim Ahmed, Saqib Kazmi, Zahoor Ali Khan, Umar Qasim, Nadeem Javaid." Monitoring of Power Transmission Lines through Wireless Sensor Networks in Smart Grid". International conference inAdvances in Intelligent Systems and Computing , DOI:10.1007/978-3-319-61542-4\_15. June2017.
- [15] Mr . Sachin .V.I,D.L.Gahe, Aushi .Mand Pravin .S.(Review on Power Line Monitoring, Using Smart Grid Technology",International Journal of Recent Innovation In Engineering and Research ,vol(02) issue (02),,(2017),pp:25-31,ISSN:2456-2084.

