

Comparative Analysis between OFDMA and SC-FDMA: Model, Features and Applications

Farjana Imam¹, Mehenaz Akter Mitu¹, Sonia Akter¹, Ety Khanam¹, Shikha Rani Das¹,
Abdullah Al-Mamun Bulbul^{1,2*}

¹Dept. of Electronics and Telecommunication Engineering, Bangabandhu Sheikh Mujibur Rahman Science and
Technology University, Gopalganj, Bangladesh,

²Electronics and Communication Engineering Discipline, Khulna University, Bangladesh,

*corresponding authors: bulbul@bsmrstu.edu.bd, bulbulmamun@yahoo.com

Abstract – This paper represents Orthogonal Frequency Division Multiple Access (OFDMA) and Single Carrier Frequency Division Multiple Access (SC-FDMA) techniques along with the Orthogonal Frequency Division Multiplexing (OFDM). The concept, model, features, scopes, applications and limitation for both types of multiple access have been discussed in this paper. In present 4G and 5G cellular communication system, both OFDMA and SC-FDMA have a notable applications. Dividing the available spectrum into overlapping orthogonal narrowband sub bands, OFDMA ensures high spectral efficiency. Besides by allocating multiple sub carriers to each user, OFDMA provides high data rate, reduces inter blockage interference, minimizes frequency selective fading and so on. But it suffers from high peak to average power ration (PAPR) which results in high power consumption at the transmitter end. SC-FDMA is capable to solve the PAPR problems. Besides it also enhances the overall cellular capacity and thereby provides higher spectral efficiency by multiplexing signals depending on individual spatial signature. In contrast, due to fixed subcarrier allocations for each user in OFDM, its performance can suffer from narrowband fading and interference.

Keywords: OFDMA, SC-FDMA, LTE, 4G, 5G.

Article History

Received 1 August 2019

Received in revised form 10 September 2019

Accepted 10 September 2019

I. Introduction

With the evaluation of newest communication technologies, need for higher speed or data rate is swelling day by day. The increasing data rate will bring a revolutionary change in the conventional way of multimedia communication, internet browsing, voice, image transmission etc. So the present generation requires a technology which is able to provide high speed data rate, with permissible BER and minimum delay. Orthogonal frequency division multiple access (OFDMA) is assumed to be that technology which will fulfill the upcoming demand. It supports large number of channels and sub-carries. But it suffers from high peak to average power ratio (PAPR) which causes amplifier problem at the transmitting terminal. So it needs a linear power amplifier. To minimize the problem of OFDMA, single carrier frequency division multiple access (SC-FDMA) technology is invented. Due to its intrinsic low PAPR and

high coverage characteristics, SC-FDMA technology is used in power constraint devices. In this paper, we have discussed on the working principle of OFDMA and SC-FDMA. A comparative analysis has been carried out between this two along with their respective features and limitations.

II. OFDMA

OFDMA is the technology which is used in the wireless 4G long-term evolution (LTE) and 4G Worldwide Interoperability-for-Microwave Access (Wi-MAX) systems [1]. It is a relevant expansion of OFDM technique that serves several users effectively and efficiently. In OFDMA, several number of users are given access simultaneously to the communication resources like shared air channels. A set of subcarriers are applied to convey data for only one user. In OFDM,

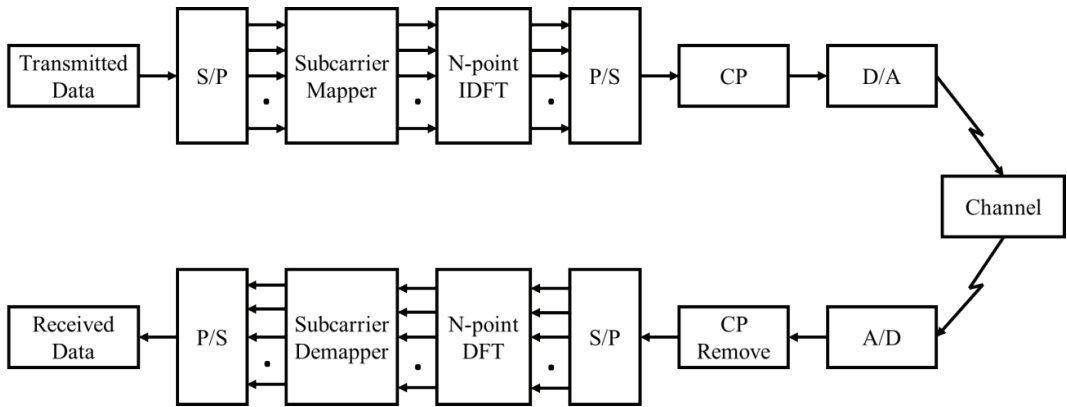

Fig. 1. Basic principle of OFDMA [2]-[4]

each user is provided with a fixed number of subcarriers that are used to transmit data in parallel manner at the same time. Since only one user can transmit data at a time, multiple users need to wait to get their turns of time to transmit data using OFDM. Instead of consecutive allocation of OFDM symbols to multiple consumers, OFDMA assigns unique set to subcarriers to each user. These enables multiple users to communicate simultaneously.

A. Objective of OFDMA

OFDMA technology is employed in 802.11ax for skillful access. OFDMA offers multiple number of users with dissimilar bandwidth which enables them to communicate simultaneously. OFDMA split the total available spectrum and assigns them to different users on demand basis. OFDMA is model applicable in for lower band operations. OFDMA ensures higher frequency reuse and more effective frequency utilization by dividing the available spectrum into several orthogonal subcarriers. Besides OFDM can effectively reduce frequency-selective fading through utilizing multiple orthogonal subcarriers. In addition, OFDMA based radio resource management possesses the liberty to select which set of frequencies to be assigned to whom both in frequency domain and time domain [5]-[6]. Global coverage seeks the capability of the system that un-interrupted provisions must be provided to every user even in the worst channel environments such as during heavy raining. The system should also ensure increased data rate and effective allocation of orthogonal subcarriers to multiple users. To achieve high data rate and coverage expansion along with enhanced capacity in an existing cellular network, cell splitting is required. Which in turns increases the number of the base station (BS) to cover a given area. Through this mechanism enhances overall system capacity, but it increases system installation cost due to high density BS [5]. OFDMA eradicates this type of problems.

B. Principle of OFDMA

Fig. 1 represents a humble block representation of OFDMA technique comprised of K number of users each have a single sub-carrier. At BS, the received signal is the totality of the K number of users' signals and behaves like an OFDM signal because of its multi-P2P nature. OFDMA needs a single demodulator which is trailed by an N point discrete Fourier transform (DFT). On the other hand, the main components of OFDMA transmitter terminal are forward error correction (FEC) channel coding, sub-carrier allocation / sub carrier mapping and a single-carrier modulator. Sometime single-carrier modulator is replaced by multi-carrier modulator if there are several numbers of sub-carriers are allocated per user. After FEC coding and symbol mapping, total data of a single user is divided into blocks of length [7] and then fed to OFDMA modulator.

Since OPSK modulation is used in OFDMA for the uplink in a multi-user environment, however, high order modulation schemes for examples 16 quadrature amplitude modulation (QAM), 64 or 128 QAM may also be engaged. The subcarrier assignment can be either fixed or dynamic. To achieve frequency diversity hopping of frequency may be desirable. This frequency hopping is usually accomplished in dynamic fashion.

The main components of receiver terminal are demodulator, A/D converter and soft detectors. Base stations possess both subcarriers and a clock in case of synchronous network. Carrier and clock recovery circuit is suitable for sucking the original information from the received signal [8].

C. Basic OFDMA System

Information is expressed in bits if digital communication is used, where a few numbers of bits are collectively called symbol [8]. OFDMA process can be divided into some sequential step as shown in Fig. 2.

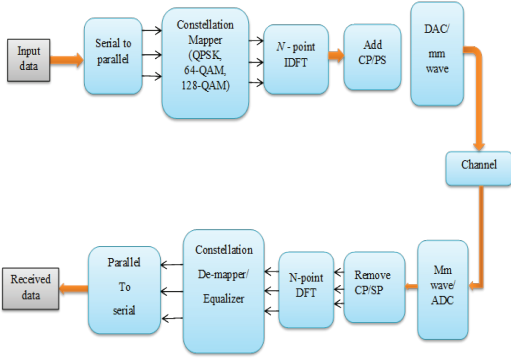

Fig. 2. Block Representation of OFDMA

Sub-carrier Mapping: The input data first converted into serial to parallel. Using QPSK, 16 QAM or 128 QAM serial to parallel converted data is modulated. Consider a_i and b_i are the data symbols assigned to the in-phase (I) and quadrature-phase (Q) of the m sub-branch.

Now all the sub-branch signals form a composite transmitted signal $s_i(t)$:

$$S_i(t) = \sum_{i=0}^{N-1} \Re\{a_i + jb_i\} \exp(2\pi f_i t) \quad (1)$$

Where, N denotes the numeral of subcarriers.

N-point IDFT: The signal is modulated with orthogonal sub-carrier using IDFT [9]. Then the modulated data is fed to a low pass filter. The corresponding transmitted signal of equation (1) is represented as follows:

$$S(t) = \frac{1}{\sqrt{N}} \sum_{i=0}^{N-1} [a_i \cos(\frac{2\pi i t}{T}) - b_i \sin(\frac{2\pi i t}{T})] \quad (2)$$

Where, a_i and b_i are data symbols

Addition of Cyclic prefix and DAC: During channel transmission orthogonality is maintained. Adding a cyclic prefix on the OFDMA frame orthogonality can be maintained [9]. Now convert the data into parallel to serial and transmit it into a beam forming multiple input multiple output (MIMO) antenna. Through the distributed sub carriers for single user OFDMA has a frequency diversity.

D. OFDMA Parameters and Characteristics

In frequency domain, the calibration parameter is effectively interpolated. Simulations evaluate the proposed calibration. In the array antenna calibrations in

frequency selection OFDMA the following simulation parameters are used. Table I shows the simulations parameters [10]. For a bandwidth of 1 GHz, the number of subcarriers is approximately 750 with a frequency spacing of 13.33 kHz. Rayleigh channel or Quasi-static Rayleigh channel is generally used to model the free space propagation environment.

TABLE I
SPECIFICATIONS ADOPTED FOR THE SIMULATED INVERTER

System	OFDMA system
<i>Bandwidth</i>	Depends on application fields (typically in GHz range)
<i>Frequency spacing</i>	Typically 13.33 kHz
<i>No. of Subcarriers</i>	For BW = 1 MHz, 75 subcarriers
<i>Channel model</i>	Typically Rayleigh channel or Quasi-static Rayleigh channel

Using OFDMA, parameters such as bandwidth, downlink (DL) / uplink (UL) peak, speed etc. are different for various technologies like LTE, ultra-mobile broadband (UMB) and worldwide interoperability for microwave access (WiMAX). The following Table II shows data rate for various technologies:

TABLE II
DATA RATE FOR DIFFERENT TECHNOLOGIES [11]

Technology	Bandwidth	DL/UL Peak
<i>LTE</i>	1.25-20 MHz FDD	100/50 Mbps
<i>UMB</i>	1.25-20 MHz FDD	33-152/17-75 Mbps
<i>Mobile WiMAX</i>	TDD 3.5 MHz, 5 MHz, 7 MHz, 8.75 MHz, 10 MHz	46/7 Mbps 2x2 MIMO in 10 Hz with 3:1;

In the following Fig. 3, the OFDMA system is represented as frequency or sub band versus time or frame. In the frequency domain, the available spectrum is partitioned into several number of sub-bands that hold orthogonality among themselves. The total partitioned subcarriers, let S , are framed into K sub-bands where every user gets $N (= S / K)$ number of subcarriers. On the other hand, frames arrange data in time domain those are separated later in time symbols. The incision between sub-bands and time symbols bounds the least apportionable resources in the overall system.

Suppose a singular cell continuity where K subscribers are present with burst traffic claim. Signal is attenuated by free space loss, multipath fading, shadowing, scattering etc. The highest subcarrier fading observed in every single sub-band takes part in the signal-to-noise ratio (SNR) calculation that is necessary for scheduling [12].

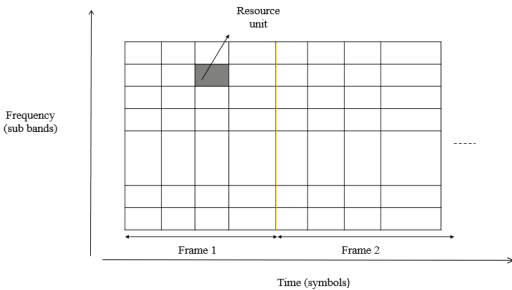

Fig. 3. Two dimensional resources in OFDMA systems

Orthogonality between two (scalar) waveforms $y_1(t)$ and $y_2(t)$ in time and frequency domain requires their inner product in signal space is to be zero. Now,

$$[y_1(t) | y_2(t)] = \int_{-\infty}^{\infty} y_1(t)y_2^*(t)dt = \int_{-\infty}^{\infty} Y_1(f)Y_2^*(f)df \quad (3)$$

$Y(f)$ is the Fourier transform of $y(t)$.

From frequency division, OFDMA gives orthogonality. The subcarriers are told to be orthogonal when their integral product for their common period is zero. For checking the orthogonality [13], we consider, An OFDMA signals contain N subcarriers. N parallel data modulate the OFDMA subcarriers. Mutual subcarriers orthogonality provides the frequency impedance on the symbol length [14]. Any two subcarriers with frequencies f_n and f_k are said to be orthogonal if they follow the below mentioned equation (4).

$$\int_0^{T_s} \sin(2\pi f_n t) . \sin(2\pi f_k t) dt = 0; \text{ for, } n \neq k \quad (4)$$

E. Advantages of OFDMA

The main advantages of OFDMA are discussed below:

Scalability: OFDMA is said to have scalability as it has the ability to scale the number of points in discrete Fourier transform (DFT) and the number of subcarriers to be assigned to any specific user.

Orthogonality: As the subcarriers are orthogonal in OFDMA, interference among sub-bands is minimized in notable amount.

MIMO friendliness: Simultaneous parallel data transmission through multiple channels is accomplished in OFDMA due to the use of MIMO antenna.

Minimization of frequency selective fading: While transmitting data through orthogonal subcarriers, a portion of the sub-bands may be affected by the fading in practice but not the whole sub-bands. So it reduces the

possibility to be affected by frequency selective fading (FSF) [15].

Spectral efficiency: OFDMA divides the available spectrum into orthogonal sub-bands. These sub-bands are overlapping and orthogonal to each other. This overlapping division of spectrum ensures high spectral efficiency.

Multi-carriers and multiple-access: A set of orthogonal subcarriers are allocated to each user in OFDMA. Since the subcarriers are orthogonal and narrowband, so the number of subcarriers is higher in OFDMA. So, hug number of users may be provided access to the system along with multiple subcarriers.

Reduced adjacent channel interference: Since the subcarriers are orthogonal to each other, adjacent subcarriers don't cause any impact on each other.

Cost effective: Employment of OFDMA system and hardware implementation is much cost effective.

Besides, OFDMA reduces multiple path distortion [16]. High order of diversity is also noticed in OFDMA.

F. Disadvantages of OFDMA

Although OFDMA comes up with great features and advantages, it also possesses few limitations. Noteworthy limitations are imposed on OFDMA while comparing with single carrier communication network. Due to the assignment of multiple subcarriers to each user, the collaborated time domain signal takes on the shape of Gaussian noise that comprised of higher peak amplitude spikes. This gives rise in PAPR. PAPR causes complexity while amplifying the signal.

Synchronization mismatch among the subcarriers gives rise to multiple access interfaces in OFDMA [17]. Due to high PAPR, OFDMA requires linear power amplifier. Due to the outflow of DFT, carrier frequency offset becomes a major issue in OFDMA [16]. The frequency diversity is contingent on how users assign subcarriers, for this it is very complex. It needs extra power because it is always ready to send a transmission. It can't provide high quality broadband services.

G. Limitations of OFDMA

One of the severe constraints of OFDMA that acutely restricted its performance in the practical applications is extensive envelope variation that causes severe nonlinear distortion. The reason behind this distortion is the use of power amplifiers that exhibits nonlinear behaviors.

Another grave limitation of OFDMA is high PAPR due to huge fluctuations in amplitude. This fluctuation causes in band noise. In addition, it raises bit error rate (BER) if radio frequency amplifiers are used in OFDMA system [18].

Another limitation of conventional OFDMA MAC protocols in terms of channel utilization and the probability of collision is the requirement for effective channel allocation.

It exhibits sensitivity to timing offset (TO) and carrier frequency offset, mainly in the uplink. It is also a major limitation of OFDMA.

H. OFDMA Applications

OFDMA shows many applications. Implementation of wireless Local Area Network (LAN) standard of IEEE 802.11ax is one of them. OFDMA is also used in the dynamism mode of IEEE 802.16 Wi-MAX wireless MAN (Metropolitan Area Network) standard of IEEE 802.20 MBWA. Again for gaining large spectral efficiency, OFDMA is used in communication.

Moreover OFDMA is also a candidate entrance technology for the IEEE 802.22 WRA (Wireless Regional Area) networks, the method of a cognitive radio where white spaces are used in the TV (Television) frequency spectrum and the downlink of 3GPP LTE (4G Standard of mobile broadband applications) [19].

III. SC-FDMA

SC-FDMA which is also known as linearly precoded OFDMA (LP-OFDMA) is a multiple access technique which takes advantage of single carrier modulation in the transmission section and frequency domain equalization in the receiving section [20]. It may be considered as a modified version of OFDMA which is used for high data rate in uplink communication. The main advantage of SC-FDMA is low PAPR than OFDMA. In modern times, SC-FDMA is used for uplink multiple access system in 4th generation (LTE) cellular system under consideration of 3GPP (Third Generation Partnership Project) [21].

A. Objectives of SC-FDMA

At present, wireless multimedia application & mobile internet become more wide-spread which requires a higher data rate and a quality of service for communication link. As a result, the selection of carrier frequency for each channel becomes additionally intense. This gives rise in the inter-symbol interference (ISI) [20]. There is a way to moderate FSF which is found in wide band carriers. To avoid this type of fading, multicarrier approach that partitions the sub-bands into narrower subcarriers is utilized. OFDMA is a multicarrier technique which maintain orthogonality to convey information [20]. By dividing the speedy data bits into multiple lower speed data bits and transmitting these lower speed data bits in parallel path, OFDM removes the

ISI [20]. But in OFDMA, there are some limitations for uplink communication like as high PAPR, elevated susceptibility to frequency difference between receiving local oscillator (LO) and transmitting LO, usually termed as offset. Besides OFDMA requires adaptive techniques in order to reduce bandwidth wastage [20]. In order to overcome those limitations, the modified version of OFDMA which is referred as SC-FDMA is used. For uplink transmission in wireless cellular system, a low PAPR is necessary. In order to avoid high power consumption in mobile terminal (transmitter for uplink), a low PAPR is necessary which is provided by SC-FDMA.

B. Principle of SC-FDMA

The theory of SC-FDMA which is accepted in 3GPP LTE standard is placed in [22]. Fig. 4 shows a block representation for SC-FDMA transmitter.

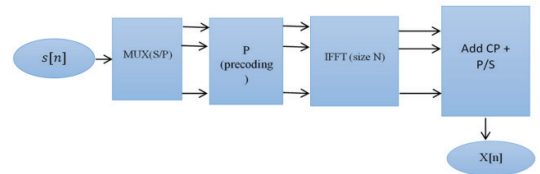

Fig. 4. Block representation for SC-FDMA transmitter

Subscriber bits, $s[n]$, are fed to a serial-to-parallel (S/P) converter which is divided into Q parallel sub-streams. Each parallel sub-streams is assigned a subcarrier in OFDMA.

On the other hand, a precoder is introduced immediately after the S/P converter in SC-FDMA [17]. Taking Q output samples from the multiplexer, the precoder again multiply with a matrix P size of $(R \times Q)$ where $R \geq Q$. Due to the choice of $R > Q$ it allows some redundancy which are used for reducing PAPR [22].

It has been marked that when $R = Q$, it defines a better selection of P in DFT matrix and if $R > Q$, P is attained by spreading the $Q \times Q$ vertical matrix. A diagonal matrix that constitutes a perfect windowing operation is pre-multiplied with the output $R \times Q$ matrix. The raised-cosine (RC) & square root RC are the two windowing operations used in above purpose.

For a clear views of the signal transmission in SC-FDMA, it is assumed as a multiple data rate digital signal processing (DSP) methods where user message bits $s[n]$ is fed into the system and the resulting signal $x[n]$ is found from the output terminal. Fig. 5 represents the multi-rate SC-FDMA transmitter which permits handling using multi-rate DSP tools. An M length tapped delay line and a collection of M -fold down-sampler are used to constitute the multiplexer. In Fig. 5, P has the dimension

$R \times Q$ which denotes the precoder matrix. Signal from P is fed to E where the signal is extended to a length of N by inserting zeroes at the starting and ending. IFFT is performed on the resulting signal from E . The block diagram for IFFT operation is represented by F^{-1} in Fig. 5. A collection of N -fold expanders is used to constitute the S/P converter. The S/P converter is trailed by a collection of shifts and add operators. Cyclic prefixing (CP) is performed on the data immediately before constituting the output signal $x[n]$.

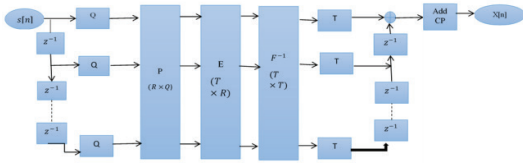

Fig. 5. Block representation of multi-rate signal processing in SC-FDMA transmitter

C. Basic SC-FDMA Systems

SC-FDMA is considered as a single carrier transmission technique. CP helps SC-FDMA to transform the multipath FSF channel into multiple flat-fading sub-channels. Besides, frequency domain equalization (FDE) is performed effectively and efficiently at the receiving end. SC-FDMA signals inherits low PAPR that highly enhances the power efficiency of individual user equipment (UEs) [23]. The following Fig. 6 shows the block representation of complete SC-FDMA system comprised of transmitting and receiving unit.

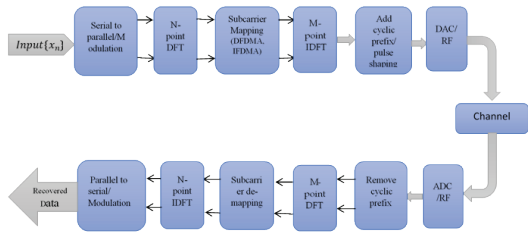

Fig. 6. Block diagram of SC-FDMA system

At first, the transmitter converts the digital (binary) message signal x_{ni} into parallel sequence. A baseband modulator at the transmitter, transforms the binary input data to a multilevel complex numbers. Firstly, transformation of these symbols from time to frequency domain by N -point DFT.

Let the k^{th} user transmitting the N symbols be revealed as below.

$$X_{k_0} = \sum_{k=0}^{N-1} x_{ni} e^{-\frac{2\pi jkn}{N}} \quad (5)$$

Where, x_{ni} is the input binary signal.

Mapping of individual N -point DFT signal to one of the $M (> N)$ orthogonal subcarriers is performed [18]. Two different types of subcarrier mapping can be performed. One is localized mode and other is distributed mode. Localized SC-FDMA is more used due to its lower PAPR compared to distributed SC-FDMA.

The next step is M -point IDFT. It can be expressed as,

$$x_m = \frac{1}{m} \sum_{l=0}^{M-1} X_l e^{\frac{2\pi jkm}{M}} \quad (6)$$

Where, X_l is the result of subcarrier mapping.

Generation of the time-domain samples of the subcarriers, where $M > N$. It is quite similar to that in the transmitter section of the downlink.

Then it is required to perform parallel to serial conversion of the data stream. Then cyclic prefixing is performed on the serial data to remove inter symbol interference. Due to insertion of cyclic prefix between two blocks to reduce inter-blockage-interference. Then conversion of the serial data from digital to analog signal is accomplished. For recovering the transmitted data, demodulation of received signal at the receiver end is performed in the reverse way as it was modulated at the transmitter.

D. SC-FDMA Parameters

In SC-FDMA technology some parameters are needed. These parameters are categorized into four items. In this technology the channel environment includes Multipath delay profile and Multipath power profile parameter. A multipath channel may be individualized in many ways for deterministic modelling and power delay profile (PDP). The time slot is imposed on a schedule. this time slot include modulation, number of user, block length, data length for user, CP length, sub time slots, symbol of time slots, received power parameter.

Symbol rate, sub-carrier frequency spacing, single carrier shaping parameters are related in signal transmission. The pulse shaping filter defines the roll-off, order, over sampling factor parameters.

E. Advantages of SC-FDMA

The SC-FDMA can fulfil free dispatch of Multiple Access Interference (MAI) for different users by using

different subcarriers [24]. For multipath channel among different users SC-FDMA maintain orthogonality among subcarriers [24].

The SC-FDMA takes great advantages of low peak-to-average power ratio characteristics and better suited for multiple users [25]. SC-FDMA is better for uplink high coverage.

For any modulation technique the SC-FDMA gives better performance and also for coding sets [28]. This technique assures easy frequency planning, lower sensitivity, high immunity against interference, reduction of fluctuation, more power efficient etc.

Due to less sensitivity, it has low cost for power amplifiers in non-linear alteration.

The elaborated interpretation of Single Carrier Frequency Domain Equalization (SC-FDE) is SC-FDMA. It can accommodate multiple access. For battery operated handsets it is a very proficient power amplifier [27].

F. Disadvantages of SC-FDMA

SC-FDMA have more advantages but it also shows some drawbacks. The operation of SC-FDMA is more complex as subcarriers are dispatched sequentially. One of the key disadvantages of SC-FDMA is inter-symbol-interference (ISI) [28]. This problem can be relieved by using the technique of interference cancellation or by using frequency domain equalization (FDE) [28].

When the receiver of SC-FDMA use linear amplifier, there are some noise enhancement that demotes the performance of the system [28]. SC-FDMA provides tenacious provision allocation and worse spectral efficiency [28]. The SC-FDMA also cannot provide higher SNR.

G. Limitations of SC-FDMA

The major limitation of SC –FDMA is that, the system is more complex in application of MIMO discovery algorithm which is not linear as it requires need to join $M \times M$ elements from every transmit antenna.

The hybrid mapping of both interleaved frequency division multiple access (IFDMA) and localized frequency division multiple access (LFDMA) of SC-FDMA is able to confirm the superior datum throughput over usual sub-carrier mapping. However this hybrid sub-carrier technique may annihilate the orthogonality properties of the users [29].

Another important limitation is that, only for multiple users (over 12) and for large bandwidth allocation (over 100 MHz) SC-FDMA can give superior spectral efficiency [30].

H. SC-FDMA Applications

SC-FDMA has created attention, as used in the uplink multiple communication scheme in the ULTRA-LTE owing to its low PAPR properties.

SC-FDMA is used to access a large number of users to a shared communication resource. Allocating dissimilar set of subcarriers to several users, multiple users are given access to the system. These subcarriers are non-overlapping.

IV. System Model Comparison between OFDMA and SC-FDMA

SC-FDMA has been applied for uplink dispatch in UTRA and LTE to get lower PAPR to reduce power consumption at mobile terminal. The natural damage of frequency diversity in OFDMA can be removed by precoded OFDMA that means SC-FDMA. This precoding is the form of DFT matrix. SC-FDMA has PAPR, frequency diversity and also allows supple of sharing of spectrum compared to OFDMA.

Different modulation techniques and coding sets like BPSK, QPSK, 16-QAM, 64-QAM, 128-QAM etc. are used in OFDMA and SC-FDMA. OFDMA shows better performance than SC-FDMA. Sectors where power is not a major concern, OFDMA is applied. For that, OFDMA has been applied in the downlink of 4G and proposed for the downlink architecture in 5G [2]. However with turbo equalizer, the SC-FDMA shows better performance for any modulation technique and coding set than OFDMA. SC-FDMA with minimum mean square error (MMSE) equalizer can get worse than OFDMA due to acute multi-user interference.

V. Conclusion

In this paper the two popular multiple access technique, the OFDMA and SC-FDMA are investigated. Both the SC-FDMA and OFDMA are selected for both uplink & downlink respectively in the present and future generation communication networks. The discussion about the concept, scope & applications of those multiple access techniques which indicates that both techniques have some virtues. Neither of them is better than the other in all conditions.

References

- [1] S. Faruque, Orthogonal Frequency Division Multiple Access (OFDMA). In *Radio Frequency Multiple Access Techniques Made Easy* (pp. 63-77). Springer, 2019.
- [2] A.A.M. Bulbul, M.T. Hasan, M.I. Kadir, M.M. Hossain, A. Al Nahid and M.N. Hasan, High-Capacity Downlink for Millimeter Wave Communication Network Architecture. In *Emerging Technologies in Data Mining and Information Security* (pp. 657-

- 666). Springer, Singapore 2019.
- [3] M. Al-Rawi. Performance analysis of OFDMA and SC-FDMA. *International Review of Applied Sciences and Engineering*, 8(2), pp.113-116, 2017.
 - [4] H.G. Myung. Introduction to single carrier FDMA. *15th European signal processing conference 2007*, pp. 2144-2148, 2007.
 - [5] M. Salem, A. Adinoyi, H. Yanikomeroglu and D. Falconer, Opportunities and challenges in OFDMA-based cellular relay networks: A radio resource management perspective. *IEEE Transactions on Vehicular Technology*, 59(5), pp.2496-2510, 2010.
 - [6] M.I. Kadir, S. Sugiura, J. Zhang, S. Chen, L. Hanzo. OFDMA/SC-FDMA aided space-time shift keying for dispersive multiuser scenarios. *IEEE Transactions on Vehicular Technology*. 62(1):408-14, 2012.
 - [7] M. Morelli, C.C.J. Kuo and M.O. Pun, Synchronization techniques for orthogonal frequency division multiple access (OFDMA): A tutorial review. *Proceedings of the IEEE*, 95(7), pp.1394-1427, 2007.
 - [8] H. Sari and G. Karam, Orthogonal frequency-division multiple access and its application to CATV networks, *European Transactions on Telecommunications (ETT)*, vol. 9, pp. 507-516, Nov./Dec. 1998
 - [9] M. Bhardwaj, A. Gangwar and D. Soni, A review on OFDM: concept, scope & its applications. *IOSR Journal of Mechanical and Civil Engineering (IOSRJMCCE)*, 1(1), pp.07-11, 2012.
 - [10] Y. Hara, Y. Yano and H. Kubo, Antenna array calibration using frequency selection in OFDMA/TDD systems. In *IEEE GLOBECOM 2008-2008 IEEE Global Telecommunications Conference* (pp. 1-5). IEEE, 2008.
 - [11] M. Ergen, *Mobile Broadband, Including WiMAX and LTE* Springer. *Science Business Media, LLC*. 2009.
 - [12] R.K. Almatarneh, M.H. Ahmed and O.A. Dobre, Performance analysis of proportional fair scheduling in OFDMA wireless systems. In *2010 IEEE 72nd Vehicular Technology Conference-Fall* (pp. 1-5). IEEE, 2010.
 - [13] P. Praveenkumar, R. Amirtharajan, K. Thenmozhi and J.B.B. Rayappan, Regulated OFDM-role of ECC and ANN: A review. *Journal of Applied sciences*, 12(4), p.301, 2012.
 - [14] L. Uryvskiy and S. Osypchuk, OFDM signal energy characteristics research in channel with permanent parameters. *Information and Telecommunication Sciences*, (2), 2013.
 - [15] H. Yin and S. Alamouti, OFDMA: A broadband wireless access technology. In *2006 IEEE sarnoff symposium* (pp. 1-4). IEEE, 2006.
 - [16] M. Bhardwaj, A. Gangwar and D. Soni, A review on OFDM: concept, scope & its applications. *IOSR Journal of Mechanical and Civil Engineering (IOSRJMCCE)*, 1(1), pp.07-11, 2012.
 - [17] S.S. Prasad, C.K. Shukla and R.F. Chisab, Performance analysis of OFDMA in LTE. In *2012 Third International Conference on Computing, Communication and Networking Technologies (ICCCNT'12)* (pp. 1-7). IEEE, 2012.
 - [18] J. Gazda, P. Drotár, P. Galajda and D. Kocur, Comparative evaluation of OFDMA and SC-FDMA based transmission systems. In *2010 IEEE 8th International Symposium on Applied Machine Intelligence and Informatics (SAMII)* (pp. 177-181). IEEE, 2010.
 - [19] C. Ciochina and H. Sari, A review of OFDMA and single-carrier FDMA. In *2010 European Wireless Conference (EW)* (pp. 706-710). IEEE, 2010.
 - [20] H.G. Myung, September. Introduction to single carrier FDMA. In *2007 15th European signal processing conference* (pp. 2144-2148). IEEE, 2007.
 - [21] H.G. Myung, J. Lim and D.J. Goodman, Single carrier FDMA for uplink wireless transmission. *IEEE Vehicular Technology Magazine*, 1(3), pp.30-38, 2006.
 - [22] C.H. Yuen, P. Amini and B. Farhang-Boroujeny, Single carrier frequency division multiple access (SC-FDMA) for filter bank multicarrier communication systems. In *2010 Proceedings of the Fifth International Conference on Cognitive Radio Oriented Wireless Networks and Communications* (pp. 1-5). IEEE, 2010.
 - [23] R.F. Chisab and C. Shukla, Performance evaluation Of 4G-LTE-SCFDMA scheme under SUI And ITU channel models. *International Journal of Engineering & Technology IJET-IJENS*, 14(1), pp.58-69, 2014.
 - [24] T.W. Yune, C.H. Choi, G.H. Im, J.B. Lim, E.S. Kim, Y.C. Cheong and K.H. Kim, SC-FDMA with iterative multiuser detection: improvements on power/spectral efficiency. *IEEE Communications Magazine*, 48(3), pp.164-171, 2010.
 - [25] C. Ciochina, D. Mottier and H. Sari, An analysis of OFDMA, precoded OFDMA and SC-FDMA for the uplink in cellular systems. In *Multi-Carrier Spread Spectrum 2007* (pp. 25-36). Springer, 2007.
 - [26] K. Raghunath and A. Chockalingam, SC-FDMA versus OFDMA: Sensitivity to large carrier frequency and timing offsets on the uplink. In *GLOBECOM 2009-2009 IEEE Global Telecommunications Conference* (pp. 1-6). IEEE, 2009.
 - [27] V.K. Trivedi, M.K. Sinha and P. Kumar, Simplified approach for symbol error rate analysis of SC-FDMA scheme over Rayleigh fading channel. *ETRI Journal*, 40(4), pp. 537-45, 2018.
 - [28] R.C. Grammenos, and I. Darwazeh, SC-FDMA and OFDMA: The two competing technologies for LTE. *UTeM*, 2010.
 - [29] P.A. Thomas and M. Mathurakani, SC-FDMA-An Efficient Technique for PAPR Reduction in Uplink Communication Systems-A Survey. *International Journal of Research in Engineering and Technology*, 3(1), pp.53-59, 2014.
 - [30] S.M. Sulong, A. Idris, and S.S. Sarmin, Performance Evaluation of Adaptive Algorithm with Linear Equalizer in MIMO OFDMA System. *Journal of Telecommunication, Electronic and Computer Engineering (JTEC)*, 9(1-3), pp.129-132, 2017.