

Single Input Fuzzy Logic Controller for Liquid Slosh Suppression

Mohd Zaidi Mohd Tumari^{1*}, Shahrizal Saat¹, Mohammad 'Afif Kasno¹, Muhammad Syahrani Johal¹, Muhamad Falihan Bahari¹ and Mohd Ashraf Ahmad²

¹Center for Robotics and Industrial Automation, Fakulti Teknologi Kejuruteraan Elektrik & Elektronik, Universiti Teknikal Malaysia Melaka, Hang Tuah Jaya, 76100 Durian Tunggal, Melaka, Malaysia

² Faculty of Electrical and Electronics, Universiti Malaysia Pahang, 26600 Pekan, Pahang, Malaysia,

*corresponding authors: mohdzaidi.tumari@utem.edu.my

Abstract – *The chaotic nature of liquid slosh and the complex fluid dynamic motion in the container makes the traditional model-based control techniques complex and difficult to synthesize in practice. This paper presents investigations into the development of single input fuzzy logic controller (SIFLC) for liquid slosh control. The proposed approach, known as the SIFLC, reduces the conventional two-input FLC (CFLC) to a single input single output (SISO) controller. Two parallel SIFLC are developed for both lateral tank position and liquid slosh angle control. With the purpose to confirm the design of control scheme, a liquid slosh model is considered to represent the lateral slosh motion. The performances of the control schemes are accessed in terms of lateral tank tracking capability, level of liquid slosh reduction and time response specifications. Supremacy of the proposed approach is shown by comparing the results with hybrid model-free Fuzzy-PID controller with derivative filter (PIDF). Finally, it is seen from the simulation results that the proposed control scheme has able to reduce the liquid slosh without unambiguously model the liquid slosh behavior.*

Keywords: *liquid slosh control, single input fuzzy logic controller, PID, fuzzy logic*

Article History

Received 20 September 2018

Received in revised form 9 January 2019

Accepted 9 January 2019

I. Introduction

It is a common fact that the unconstrained free surface of liquid has a tendency to cause large splash, even for a very small movement of the container. The motion of the free liquid surface inside the container is named slosh. Liquid sloshing can affect the performance of the system because it exerts an additional force and moments. Therefore, liquid sloshing has been a significant problem in several areas. For example, in the ship industries, the dynamic behavior of a vessel at sea is critically affected by the dynamics of moving partly filled tanks carried onboard [1]. In the metal industries, the pouring work has been generally employed by human operator that generates sloshing to the molten metal. Then, the molten metal often overflows out of the ladle due to the excessive sloshing, and dust, air bubble and inclusion are also trapped in the molten metal [2]. Besides, the fluid slosh forces and dynamic load transfers in the lateral and longitudinal directions and parametric uncertainties caused by moving liquid cargo affect the overall dynamics of the vehicle [3]. For that reason, it is essential to

eliminate this residual liquid slosh resulting from the container motion.

Nevertheless, controlling liquid slosh still faces several degrees of complications that need to be addressed before they can be used in abundance in everyday real-life applications. The control issue of the liquid slosh is to design the controller so that the liquid tank can reach a desired position or track a prescribed trajectory precisely with minimum liquid slosh angle. In order to achieve these objectives, numerous studies have attempted to suppress the liquid slosh. Various passive methods are used to control slosh due to the no availability of the measurement of the slosh. For example, passive elements such as slosh absorbers and baffles are essentially used to dissipate the slosh energy [4]-[5]. These methods increase weight, construction time and complexity. Another method in suppressing the liquid slosh are based on open-loop and closed-loop control. For instance, input shaping technique [6]- [7], combined input shaping and command smoothing [8], filtering techniques [9] and minimum time feedforward control [10] are used to generate a prescribed motion, which minimized the residual liquid slosh. These

methods are able to decrease the liquid slosh without using the feedback sensors. Regrettably, these open-loop control schemes are very poor in handling with any disturbances occurred. Instead, feedback control or closed-loop control, which is well known to be less sensitive to disturbances and parameter variations, has also been adopted for reducing the liquid slosh. These include active force control (AFC) [11], PID control [12]-[13], H_∞ control [14], sliding mode control [15] and Variable Gain Super-twisting Algorithm (VGSTA) for output feedback control [16].

Most of the open literatures on the liquid slosh control were concentrated mainly on the model-based control schemes. Unfortunately, it has conclusively been shown that the model-based control schemes are difficult to apply in practice and do not precisely consider the chaotic nature of liquid slosh and the complex fluid dynamic motion in the container. Thus, a model-free approach will be more attractive. On the other hand, a model-free Fuzzy Logic Controller (FLC) would provide us a promising approach for the liquid slosh suppression. FLC has been widely used because this controller is quite useful in terms of reliability and robustness. FLC is simple to control, low cost and the possibility to design without knowing the exact mathematical model of the system as known as model-free. FLC system has been widely used on the various application such as in [17]-[20], however, for liquid slosh suppression are still lacking. Although FLC control methods are very promising for solving those system control problems, they require substantial computational power because of complex decision making processes. However, it is possible to take full benefits of FLC for liquid slosh suppression if the computational time of FLC is decreased.

In this paper, the Single Input Fuzzy Logic Controller (SIFLC) is suggested. The SIFLC is a simplification of the conventional FLC (CFLC). It is succeeded by applying the signed distance method [21] where the input to SIFLC is only one variable known as "distance". This is difference to the CFLC which requires an error and the derivative error as its inputs. The reduction in the number of inputs simplifies the rule table to one-dimensional, letting it to be a single input single output (SISO) controller. Thus, it can be a practical controller for liquid tank system. Two parallel SIFLC structures (comprise of two feedback loops) are considered. (1) The position error and the velocity of the cart position will be the inputs for the first SIFLC. (2) The slosh angle error and the velocity of the slosh angle will be the inputs to the second SIFLC. The objective of the design is to actuate the system to a certain cart position with minimal slosh angle. To prove the efficacy of the proposed control scheme, a liquid slosh model in [22] which consists of a small motor-driven liquid tank performing a rectilinear motion is considered. Then, the performance of the proposed method is assessed in term of level of slosh reduction and cart's position tracking capability. The result obtained is compared with recently published articles based on hybrid model-free Fuzzy-PID controller with derivative filter [23]. Finally, it

is concluded that the proposed SIFLC is yielding superior performance for liquid slosh suppression.

The brief outline of this paper is as follows. In Section II, the liquid slosh model is described. In Section III, the SIFLC method is explained. Simulation results and discussion are presented in Section IV. Finally, some concluding remarks are given in Section V.

II. Modelling of Liquid Slosh

This section provides a brief description on the modelling of liquid slosh as a basis of a simulation environment for the development and assessment of the SIFLC technique. A liquid slosh model in [22] that performing rectilinear motion as shown in Fig. 1 is considered. Sloshing is represented by an equivalent mechanical model to provide a physical interpretation of a fluid free surface. Commonly used models are spring-mass-damper and a pendulum. The representation of lateral sloshing by a simple pendulum has been widely reported in [22]. Herein, a sloshing liquid modelled by a simple pendulum having a slosh mass, m and length, l is considered. Pendulum angle, θ represents the slosh angle. The system is like a moving rigid mass coupled with a simple pendulum as shown in Fig. 2.

The system parameters are as follows:

- M : mass of the tank and liquid
- m : mass of pendulum (slosh mass)
- l : hypotenuse length of the slosh (length of pendulum)
- u : force applied for translational motion
- y : displacement of rigid tank
- Y : displacement of m in the horizontal direction
- Z : displacement of m in the vertical direction
- θ : pendulum angle (slosh angle)
- g : gravity
- d : damping coefficient

Referring to Fig. 2,

$$Y = l \sin \theta + y \quad (1)$$

$$Z = l - l \cos \theta \quad (2)$$

The kinetic energy is

$$T = \frac{1}{2} M (\dot{y})^2 + \frac{1}{2} m (\dot{Y})^2 + \frac{1}{2} m (\dot{Z})^2 \quad (3)$$

The potential energy is

$$V = -mgl \cos \theta \quad (4)$$

The Lagrangian of the system is

$$L = T - V \quad (5)$$

Then, the Euler-Lagrange equations in y and θ , which produce dynamic equations of the system, is given by

$$M\ddot{y} + ml \cos \theta \ddot{\theta} - ml \dot{\theta}^2 \sin \theta = u, \quad (6)$$

$$ml \cos \theta \ddot{y} + ml^2 \ddot{\theta} + d\dot{\theta} + mgl \sin \theta = 0, \quad (7)$$

Therefore, the control objective is to suppress the slosh angle θ in a moving tank while achieving a desired position y . The system parameters are depicted in Table I. Note that these parameters depend on the liquid fill ratio, tank geometry and liquid characteristics. These parameters have been identified using a quick-stop experiment as reported in [24].

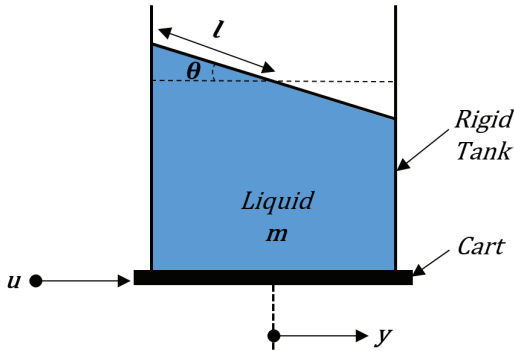

Fig. 1. Liquid slosh motion

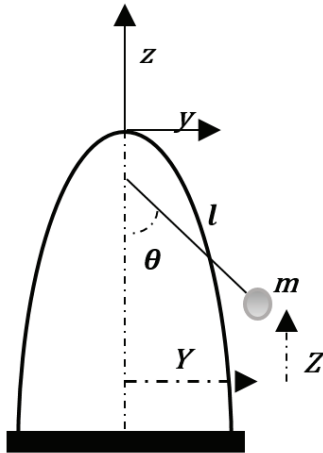

Fig. 2. Slosh mass modeled by pendulum

TABLE I
PARAMETERS OF LIQUID SLOSH MODEL

Parameter	Value	Unit
M	6.0	kg
m	1.32	kg
l	0.052126	m
g	9.81	ms^{-2}
d	3.0490×10^{-4}	kgm^2/s

III. Single Input Fuzzy Logic Controller Design

In this section, the SIFLC for liquid slosh suppression of a liquid tank system is proposed. The main objective of this control scheme is to achieve good performance in

input tracking of cart position with minimal slosh angle. FLC is a linguistic based controller that tries to imitate the way human thinking in solving a certain problem by means of rule inferences. Naturally, a FLC has two controlled inputs, namely error (e) and the change of error (\dot{e}). Its rule table can be generated on a two-dimensional space of the phase-plane (e, \dot{e}) as shown in Table II. It is common for the rule table to have the same output membership in a diagonal direction. Furthermore, each point on the certain diagonal lines has a magnitude that is relative to the distance from its main diagonal line L_z . This is known as the Toeplitz structure. The Toeplitz property is true for all FLC types which use the error and its derivative terms, namely $\dot{e}, \ddot{e} \dots$ and $e^{(n-1)}$ as input variables [25].

TABLE II
RULE TABLE WITH TOEPLITZ STRUCTURE

$e \backslash \dot{e}$	PL	PM	PS	Z	NS	NM	NL
NL	Z	NS	NM	NL	NL	NL	NL
NM	PS	Z	NS	NM	NL	NL	NL
NS	PM	PS	Z	NS	NM	NL	NL
Z	PL	PM	PS	Z	NS	NM	NL
PS	PL	PL	PM	PS	Z	NS	NM
PM	PL	PL	PL	PM	PS	Z	NS
PL	PL	PL	PL	PL	PM	PS	Z

By noticing the consistent patterns of the output memberships in Table II, there is a chance to simplify the table significantly. As an alternative of using two-variable input sets(e, \dot{e}), it is possible to obtain the corresponding output, u_0 using a single variable input only. The importance of the reduction was first realized by Choi et al. and is known as the signed distance method [21]. The method simplifies the number of inputs into a single input variable known as distance, d . The distance signifies the absolute distance magnitude of the parallel diagonal lines (in which the input set of e and \dot{e} lies) from the main diagonal line L_z . To derive the distance, d variable, let $Q(e_0, \dot{e}_0)$ be an intersection point of the main diagonal line and the line perpendicular to it from a known operating point $P(e_1, \dot{e}_1)$, as illustrated in Fig. 3.

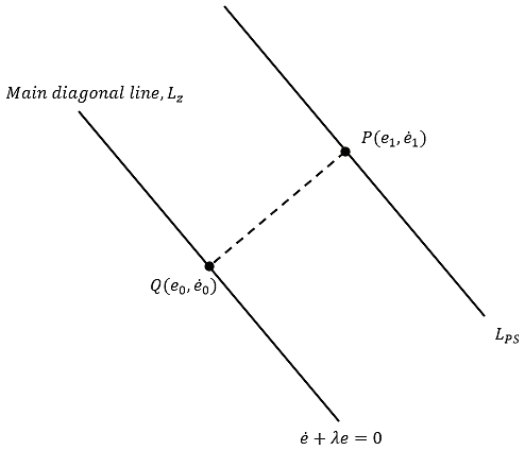

Fig. 3. Derivative of distance variable

It can be seen that the main diagonal line can be represented as a straight line function,

$$\dot{e} + \lambda e = 0 \tag{8}$$

Variable λ is the slope magnitude of the main diagonal line L_Z . The distance d from point $P(e_1, \dot{e}_1)$ to point $Q(e_0, \dot{e}_0)$, can be derived as [25]:

$$d = \frac{\dot{e} + \lambda e}{\sqrt{1 + \lambda^2}} \tag{9}$$

The derivation of distance input variable lead to a one-dimensional rule table, in difference to a two-dimension

table required by CFLC. The reduced rule table is presented in Table III, where $L_{NL}, L_{NM}, L_{NS}, L_Z, L_{PS}, L_{PM}$ and L_{PL} are the diagonal lines of Table II. The diagonal lines relate to the new input of this rule table, while NL, NM, NS, Z, PM and PL represent the output of corresponding diagonal lines. As can be recognized, the control action of FLC is now exclusively determined by d . It is therefore suitable to call it the Single Input FLC (SIFLC).

The structure of SIFLC derived from the signed distance method can be illustrated as a block diagram in Fig. 4. Two system state variables e (error) and \dot{y} (velocity) are selected as the feedback signal. The input to the FLC block is the distance variable d , while the output from FLC block is the change of control output \dot{u}_0 . The final output of this FLC is obtained by multiplying \dot{u}_0 with the output scaling factor, denoted as r . The output equation can be written as:

$$u = \dot{u}_0 r \tag{10}$$

Accordingly, the slope magnitude, λ was set to -1 while the output scaling factor, r for cart position tracking and liquid slosh angle were deduced as 26 and -17 respectively. The complete control structure of the proposed controller which consists of two parallel SIFLC for evaluation of performance of the control scheme. Fig. 6 shows the simulation setup done in MATLAB/Simulink.

TABLE III
THE REDUCED RULE TABLE USING THE SIGNED DISTANCE METHOD

d	L_{NL}	L_{NM}	L_{NS}	L_Z	L_{PS}	L_{PM}	L_{PL}
u_0	NL	NM	NS	Z	PS	PM	PL

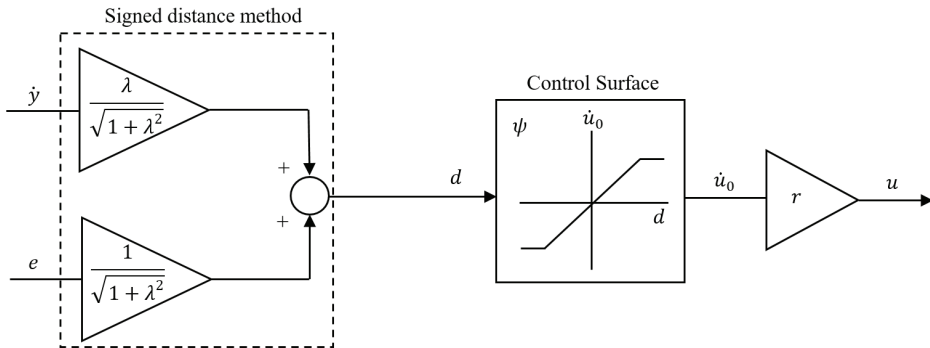

Fig. 4. SIFLC structure for liquid slosh suppression with linear control surface

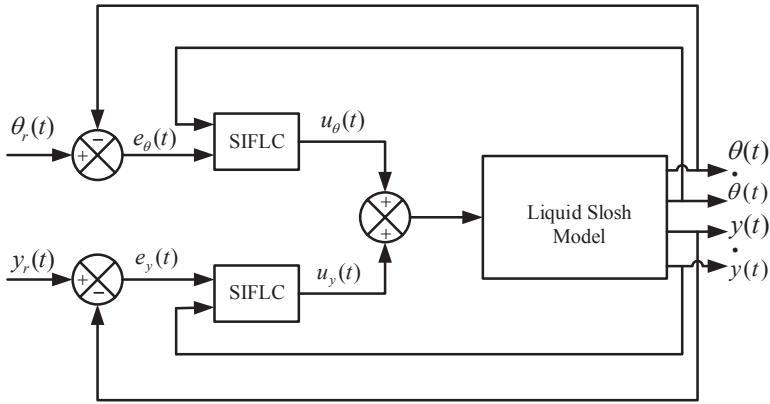

Fig. 5. Block diagram of SIFLC structure for liquid slosh suppression

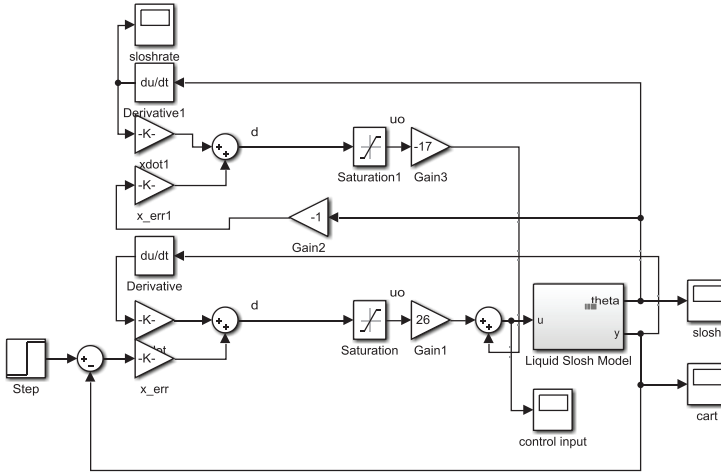

Fig. 6. SIFLC in MATLAB/Simulink

IV. Implementation and Results

In this section, the proposed control scheme is implemented and tested within simulation environment of the liquid tank system and the corresponding results are presented. The performances of the control schemes are assessed in terms of input tracking capability and liquid slosh suppression in time domain. Zero initial conditions were considered with a step input of 0.5 meter. The reference of the cart position is given by

$$r(t) = \begin{cases} 0, & 0 \leq t \leq 0.5s, \\ 0.5m, & 0.5 < t \leq 10s. \end{cases} \quad (11)$$

The simulation results are considered as the system response under liquid tank motion control and will be used to evaluate the performance of the proposed control scheme. The response of cart position, liquid slosh angle, slosh rate and control inputs are depicted in Figs. 7 to 10 for system with SIFLC and Fuzzy-PIDF. Fig. 7 shows that

the tank settles to the desired position (0.5m) in about 2.5 s for SIFLC while for Fuzzy-PIDF is 7.5 s. As we can see, the rise time for SIFLC and Fuzzy-PIDF controller is 1.5 s and 3.5 s, respectively. It is noted that, no overshoot occurred for both controllers. However, a noticeable amount of liquid slosh occurs during the movement of the cart.

Slosh is regulated nicely, as shown in Fig. 8 and Fig. 9 for both controllers. The slosh is settles within 4 s for SIFLC while for Fuzzy-PIDF controller, the slosh is settles within 8 s. Fuzzy-PIDF has a bigger slosh with a maximum residual of ± 0.1 radian compared to SIFLC with only ± 0.035 radian as shown in Fig. 8. From the Fig. 9, SIFLC has a better slosh rate with maximum residual ± 0.22 radian/sec as compared to Fuzzy-PIDF with ± 1.1 radian/sec. Fig. 10 shows the necessary control efforts. The control signal overshoots for a very short period (0.5s) when there is a step change in the command signal. SIFLC has a less overshoot with 2 Newton compared to Fuzzy-PIDF with 12.5 Newton and both control inputs are settles

at 4s. Hence, we can confirm that the SIFLC has a good potential in reducing the liquid slosh while maintaining the desired cart position. The time response specifications

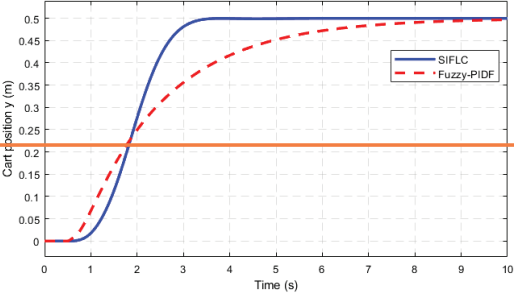

Fig. 7. Cart position response

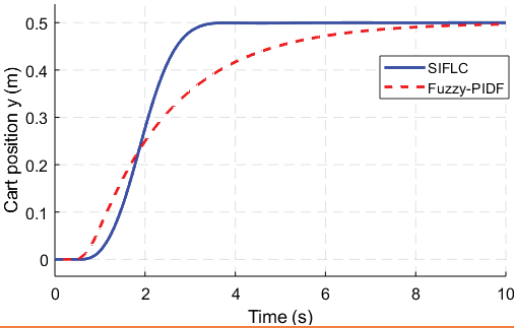

Fig. 8. Slosh angle response

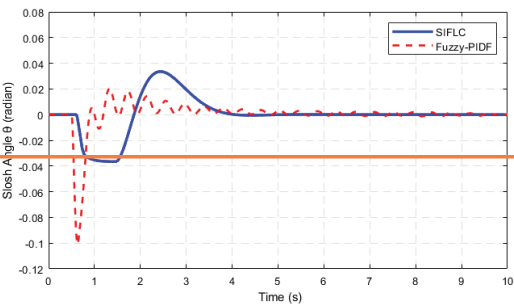

Fig. 9. Slosh rate response

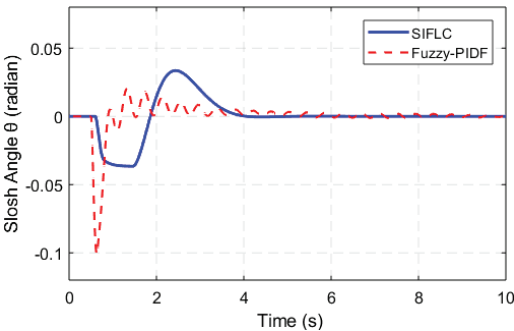

Fig. 10. Control input response

of cart position and maximum slosh angle is summarized in Table IV.

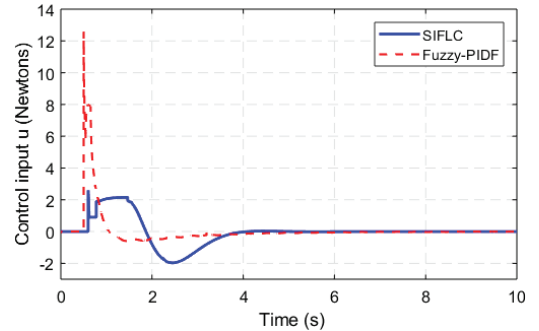
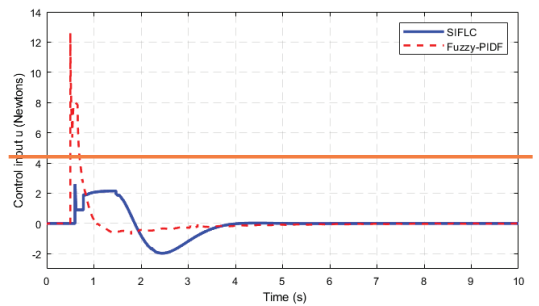
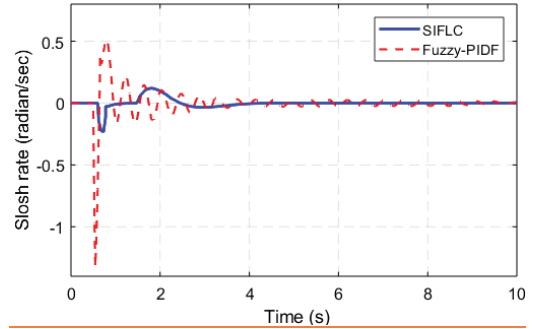
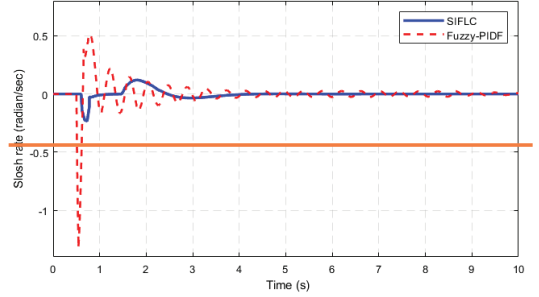

TABLE IV
TIME RESPONSE SPECIFICATIONS OF LIQUID SLOSH SYSTEM

Controller	Settling Time, T_s (s)	Rise Time, T_r (s)	Percentage Overshoot, %OS (%)	Steady State error	Maximum Slosh angle, θ (radian)	Maximum Slosh rate (rad/sec)	Control input Overshoot (N)
Hybrid Fuzzy-PIDF	7.5	3.5	0	0	0.100	1.11	12.5
SIFLC	2.5	1.5	0	0	0.035	0.22	2.0

V. Conclusion

In this study, the development of SIFLC for liquid slosh suppression has been presented. The proposed method has been tested to liquid slosh model. Gains of the proposed controller are obtained using the heuristic method based on time response behavior of the system. It is noted that significant improvements are obtained with SIFLC controller compared to hybrid Fuzzy-PIDF. The simulation results demonstrate that the proposed control approach yields a minimal liquid slosh while achieving the desired cart position. From above analysis and discussion, it is assured that the proposed control technique may become a suitable controller for solving the liquid slosh problem in aforementioned industries. Nevertheless, the implementation of SIFLC requires a large amount of design effort to tune output scaling factor, r in order to achieve the better performance. What is now needed is a study involving the optimal tuning of gains of controller using soft computing optimization techniques. Further investigation and experimentation for an online model-free technique might be investigate using a motor-driven liquid slosh experimental rig.

Acknowledgements

This work was supported by Faculty of Electrical & Electronic Engineering Technology, Universiti Teknikal Malaysia Melaka, especially Robotic, Industrial and Automation (RIA) Research Group under research grant PJP/2018/FTK(10B)/S01610.

References

- [1] P. Krata, "Linear Characteristics of the Sloshing Phenomenon for the Purpose of On-Board Ship's Stability Assessment," *Journal of Theoretical and Applied Mechanics*. 47 (2). pp. 307-320. 2009.
- [2] K. Terashima and K. Yano, "Sloshing analysis and suppression control of tilting-type automatic pouring machine," *Control Engineering Practice*. Vol 9. pp. 607-620. 2001.
- [3] T. Acarman and U. Ozguner, "Rollover prevention for heavy trucks using frequency shaped sliding mode control," *International Journal of Vehicle Mechanics and Mobility*. Vol. 44 (10). 2006.
- [4] B. U. Guzel, M. Gradinscak, S. E. Semercigil and O. F. Turan, "Control of Liquid Sloshing in Flexible Containers: Part 1. Added Mass," in *15th Australasian Fluid Mechanics Conference, Sydney, Australia, 13-17 December 2004*.
- [5] A. P. March, M. Prakash, S. E. Semercigil and O. F. Turan, "A shallow-depth sloshing absorber for structural control," *Journal of Fluids and Structures*, vol. 26. pp. 780-792. 2010.
- [6] A. Alsaibie and W. Singhose, "Experimental Testing of Liquid Slosh Suppression in a Suspended Container with Compound-Pendulum Dynamics," in *2013 9th Asian Control Conference (ASCC)*, Istanbul, 2013, pp. 1-6.
- [7] A. Samba Murthy, A. Kivila and W. Singhose, "Slosh Suppression of a Liquid in a Suspended Container using Robust Input Shaping," in *19th International Congress on Sound and Vibration*, Vilnius, Lithuania, July 8-12. 2012. pp. 1-8.
- [8] Q. Zang, J. Huang and Z. Liang, "Slosh Suppression for Infinite Modes in a Moving Liquid Container." *IEEE/ASME Transactions on Mechatronics*. Vol. 20 (1). pp. 217-225. 2015.
- [9] L. Moriello, L. Biagiotti, C. Melchiorri and A. Paoli, "Control of Liquid Handling Robotic Systems: a Feed-Forward Approach to Suppress Sloshing," in *IEEE International Conference on Robotics and Automation (ICRA)*, Singapore, May 29-June 3, 2017. pp. 4286-4291.
- [10] L. Consolini. A. Costalunga. A. Piazzzi and M. Vezzosi, "Minimum-time feedforward control of an open liquid container," in *IECON 2013 - 39th Annual Conference of the IEEE Industrial Electronics Society*, Vienna, 2013, pp. 3592-3597.
- [11] D. Setyo Purnomo, A. R. Anom Besari and Z. Darojah, "Control of Liquid Sloshing Container using Active Force Control Method," *IOP Conf. Series: Materials Science and Engineering*. Vol. 190. pp. 1-8. 2017.
- [12] M. A. Ahmad, M. A. Rohani, R. M. T. Raja Ismail, M. F. Mat Jusof, M. H. Suid and A. N. K. Nasir, "A Model-Free PID Tuning to Slosh Control using Simultaneous Perturbation Stochastic Approximation," in *2015 IEEE International Conference on Control System, Computing and Engineering (ICCSCE)*, George Town, 2015, pp. 331-335.
- [13] N. S. Abdul Shukor, M. A. Ahmad and M. Z. Mohd Tumari. "Data-driven PID Tuning based on Safe Experimentation Dynamics for Control of Liquid Slosh," in *IEEE 8th Control and System Graduate Research Colloquium (ICSGRC), 4-5 August 2017, Shah Alam, Malaysia*. pp. 62-66.
- [14] B. Robu, L. Baudouin, C. Prieur and D. Arzelier, "Simultaneous H-infinity vibration control of liquid/plate system via reduced-order controller," *IEEE Transactions on Control Systems Technology, Institute of Electrical and Electronics Engineers*. Vol. 20(3). pp 700-711. 2012.
- [15] S. Kurode, S. K. Spurgeon, B. Bandyopadhyay and P. S. Gandhi, "Sliding Mode Control for Slosh-Free Motion Using a Nonlinear Sliding Surface," *IEEE/ASME Transactions on Mechatronics*. Vol. 18(2). pp. 714-724. 2013.
- [16] J. P. Mishra and S. R. Kurode, "Robust Output-Feedback Control for Container-Slosh System using Variable Gain Super-Twisting Algorithm," in *13th IEEE Workshop on Variable Structure Systems*, Nantes, France. June 29-July 2, 2014. pp. 1-6.
- [17] M. R. Ghazali, Z. Ibrahim, M. H. Suid, M. S. Saealal and M. Z. Mohd Tumari, "Single Input Fuzzy Logic Controller for Flexible Joint Manipulator," *International Journal of Innovative Computing, Information and Control*. Vol. 12 (1). pp. 181-191. 2016.
- [18] M. A. Zawawi, J. Bidin, M. Z. Mohd Tumari and M. S. Saealal, "Investigation of Classical and Fuzzy Controller Robustness for Gantry Crane System Incorporating Payload," *Third International Conference on Computational Intelligence, Modelling and Simulation (CIMSIM)*, Langkawi, Malaysia, Sept 20-22, 2011. pp. 141-146.
- [19] M. A. Ahmad, M. Z. Mohd Tumari and A. N. K. Nasir. Composite Fuzzy Logic Control Approach to a Flexible Joint Manipulator. *International Journal of Advanced Robotic Systems*. Vol. 10 (58). pp. 1-9. 2012.
- [20] M. S. M. Aras, M. Sulaiman, A. Khamis, M. H. Hairi, M. M. Ghazaly, M. K. M. Zambri and H. N. M. Shah, "Evaluation of Transient Response for Rotary Inverted Pendulum Positioning using Fuzzy Logic Controller," *International Journal of Electrical Engineering and Applied Sciences*. Vol. 1, No. 1, pp. 9-16, 2018.

- [21] B. J. Choi, S. W. Kwak and B. K. Kim. "Design and Stability of Single-Input Fuzzy Logic Controller," *IEEE Trans. Syst. Man Cybern., Part B, Cybern.*, vol. 30, no.2., pp. 303-309. 2000.
- [22] H. N. Abramson. Analytical representation of lateral sloshing by mechanical models. *NASA, Washington, DC, NASA Rep. SP-106*. pp. 199-224. 1966.
- [23] M.Z. Mohd Tumari, W.N. Abd Rashid, N.A. Ab Hadi, M.A. Ahmad, M.H. Suid and M.R. Ghazali, "Liquid Slosh Suppression by using Hybrid Model-Free Fuzzy-PID Controller with Derivative Filter," *Journal of Advanced Research in Dynamical and Control Systems*. Vol. 10 (Special Issue). pp. 1423-1433. 2018.
- [24] K. Joshi. Modelling and analysis of fluid slosh under translation and pitching excitation. *M. S. Thesis, Indian Institute Technology, Bombay, India, 2006*.
- [25] S. M. Ayob, N. A. Azli and Z. Salam, "PWM DC_AC converter regulation using a multi-loop single input fuzzy PI controller," *J. Power Electron*, vol.9, no. 1, pp. 124-131, 2009