

Air Filter Dust Level Sensing System Using Fuzzy Logic

¹Zhen Ting Bong, ^{2,*}Kim Seng Chia, ³Abu Ubaidah Shamsudin

^{1,2,3}Department of Mechatronic and Robotic Engineering,

Faculty of Electrical and Electronic Engineering,

Universiti Tun Hussein Onn Malaysia,

¹bongzhenting@gmail.com, ^{2,*}kschia@uthm.edu.my, ³ubaidah@uthm.edu.my

Abstract – *The conventional air filter dust level checking process needs to manually inspect an air conditioner. This process is dangerous for users because the installation of the air conditioner is high. Hence, this study demonstrates a proposed air filter dust level sensing system that can automatically inspect the dust level inspection and reduce the relying on human visual inspection which is subjectively and tedious. The proposed system employs Ohm's law for sensing the current of the fan motor of an air conditioner, and employs fuzzy logic controller to estimate the dust level. The current of the fan motor would be processed to determine the relationship between the air filter blockage conditions. The finding shows that the current was proportional to the air filter blockage condition. The lowest current value was 0.2742A for no air filter blockage whereas the highest current value was 0.2898A for full air filter blockage. The system contributes to the society for having a better life as the system is promising to be adapted to inform the users about the air filter dust level of their air conditional.*

Keywords: *Dust level; Sensing system; Fuzzy logic; Air filter;*

Article History

Received 14 July 2018

Received in revised form 8 August 2018

Accepted 8 August 2018

I. Introduction

Since Malaysia has a humid and hot climate, the air-conditioning plays an important role towards achieving a comfort level in terms of thermal sensations. A study shows that approximately 44% of the energy bill is for air conditioners. A dirty coil reduces the air conditioner system's ability to cool home and causes the system to run longer, increasing the energy costs and shortening the life of the air conditioner. A dirty coil can raise energy bill by 30%. Changing or cleaning the air filter on an air conditioner can save up to 5% on the electricity bill by maintaining the efficiency of the air conditioner [1].

When an air conditioner draws in the surrounding air, the dust will also be drawn in. The air conditioner will not work properly if the air filter and cold heat exchanger coil is dirty. The air filter and cold heat exchanger coil require a regular maintenance for the air conditioner to function effectively and efficiently. In other words, neglecting a regular maintenance will cause a decline in air conditioning performance and an increase in energy consumption. The most important maintenance task that ensures the efficiency of the air conditioner is to clean the air filter routinely. This is because the dirty air filter will block the air flow and in

turn to reduce the system's efficiency significantly. With the air flow obstructed, the air that bypasses the air filter carries the dust directly into the cold heat exchanger coil and impairs the coil's heat-absorbing capacity. Consequently, the heat exchange rate decreases. A clean filter can prevent the cold heat exchanger coil from soiling quickly. Thus, the air filter is used to prevent the dust into the cold heat exchanger coil. However, the cold heat exchanger coil will still collect the dust [2][3]. The conventional air filter dust level checking process needs to open the air conditioner. This process is inconvenience and dangerous as the users have to always open the air conditioner and may fall down from ladders because the installation height of an air conditioner is normally high.

II. Literature Review

A. Structure of Air Conditioner

A general air conditioning system consists of three main components which are an air filter, a cold heat exchanger coil, and a fan. The air filter is placed in front of the cold heat exchanger coil. The cold heat exchanger coil is made up of an evaporator coil, a

condenser coil, a compressor, and an expansion valve. The fan is attached to an electrical motor to produce air flow to the system [4].

B. Working Principle of Air Conditioner

An air conditioner works by taking the surrounding air, passing it through a layer of filter and a cold heat exchanger coil to cool down the air temperature, and discharge it into the surroundings again to regulate the room temperature. The function of the filter is to prevent the dust from sticking to the cold heat exchanger coil. If the cold heat exchanger coil is filled with the dust, the heat exchange rate will decrease. Consequently, the warm air drawn in cannot be efficiently cool down by the cold heat exchanger coil as the dust works as a heat insulator, and causes the performance of the air conditioner drops [2]. The efficiency of the air conditioning system will be decreased when the air filter becomes dirty [5].

The air conditioner starts to operate when a cold liquid flows across the evaporator coil to absorb heat. The liquid is then becoming a hot gas. The compressor moves the hot gas to the condenser coils that give off the heat of the hot gas for condensing back into a warm liquid. The warm liquid is passed through the expansion device that decreases the temperature and pressure of the liquid [4][6]. The fan is used to return the cooled air to the room or push the warm air out of the exhaust [4].

C. The Configuration of Fuzzy Logic Controller

The fuzzy logic control is based on the use of the transfer functions. It is obtained from the analysis of the process of the systems. A characteristic of the methods using the fuzzy logic control is a set of the rules that consist of a set of the conditions and conclusions [7].

The basic configuration of a fuzzy logic controller consists of four main parts which are fuzzification interface, knowledge base, inference engine, and defuzzification interface. The function of the fuzzification interface is to transform the numerical data from the input to the linguistic terms. For the knowledge base, it provides necessary information for all the components of the fuzzy logic controller. The inference engine is the brain of the fuzzy logic controller that simulates the decision-making of human beings. The achieved result from the inference engine is in terms of fuzzy value that cannot be directly used to control the process of the systems. Thus, the defuzzification interface is used to defuzzify the fuzzy value to obtain the crisp value [8].

D. Advantages of Fuzzy Logic Controller

The uses of the fuzzy logic controllers have a better performance than the conventional control methods

because they allow the system to quickly analyze data and obtain more accurate results. Through the comparison between the uses of the fuzzy logic controllers and the conventional control methods, the fuzzy logic controllers perform their task with a simpler algorithm that can be easily implemented on a microcontroller. The nonlinear systems can be controlled using the fuzzy logic controllers because they are independent of the mathematical model of the systems, so the fuzzy logic control eliminates regulatory shortcomings [7][8]. Many advantages of the fuzzy logic control including powerful anti-interference, more rapid action, high operation reliability, and easy migration without changing the structure of the systems [7].

III. Methodology

A. Block Diagram

Fig. 1 shows that the block diagram of the air filter dust level sensing system for the air conditioner. The main components of the system are a current sensing circuit, an air conditioner fan motor, a Simulink software, a fuzzy logic controller, an Arduino microcontroller board, and LED indicators. The Arduino microcontroller board acts as a microcontroller to control all the components of the system. Simulink is used for configuring and accessing the system. The current sensing circuit senses the current flow from the air conditioner fan motor. The sensed current was passed through the fuzzy logic controller to generate the dust level that represented by LED indicators.

B. Circuit Design

Fig. 2 shows that the circuit diagram of the air filter dust level sensing system for the air conditioner. The LED indicators were connected to the digital inputs of the Arduino board whereas the current sensing circuit was connected to the analog input of the Arduino board. Each LED indicator was connected to a resistor with 220Ω to prevent themselves burn due to excessive current. The current sensing circuit incorporates the concept of the subtracting amplifier and Ohm's law. By using Superposition Theorem Equation 1, Equation 2 was produced based on the connection that illustrated in Fig. 2.

$$V_{R5} = 0: \frac{V_{-1}}{V_{R2}} = \frac{R_1}{R_1 + R_2} \quad (1)$$

$$V_{R2} = 0: \frac{V_{-2}}{V_{R5}} = \frac{R_2}{R_1 + R_2} \quad (2)$$

Equation 3 is the equation for comparator IC 741 and Equation 4 is a voltage divider based on the connection that illustrated in Fig. 2.

$$V_+ = V_- = V_{-1} + V_{-2} \quad (3)$$

$$\frac{V_+}{V_{R5}} = \frac{R_4}{R_3 + R_4} \quad (4)$$

Substitute Equation 3 into Equation 4 produces Equation 5, in which $R_1=R_2$ and $R_3=R_4$. The relationship between V_{R5} , V_{R3} and V_{R2} are stated in Equation 6.

$$V_{R5} = (1 + \frac{R_1}{R_2})(\frac{R_4}{R_3 + R_4} V_{R3} - \frac{R_1}{R_1 + R_2} V_{R2}) \quad (5)$$

$$V_{R5} = V_{R3} - V_{R2} \quad (6)$$

Since rated $I = 0.3A$, substitute $I = 0.3A$ and $R_s = 10\Omega$ into Equation 7, we get $V_{R5} = 3V$.

$$V_{R5} = IR_5 \quad (7)$$

$R_s = 15\Omega$ was chosen because the maximum $V_{R5} = 3V$ which is below $5V$, so that V_{R5} is compatible with the Arduino board. By using Equation 8, we can deduct Equation 9 to calculate the current value.

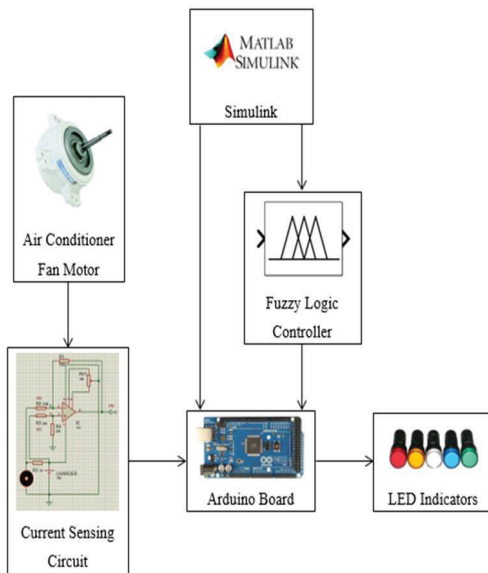

Fig. 1. Block diagram of the system

$$\frac{V_{R5}}{5} = \frac{ADC \text{ Value of } V_{R5}}{2^{10} - 1} \quad (8)$$

$$I = \frac{ADC \text{ Value of } V_{R5}}{3069} \quad (9)$$

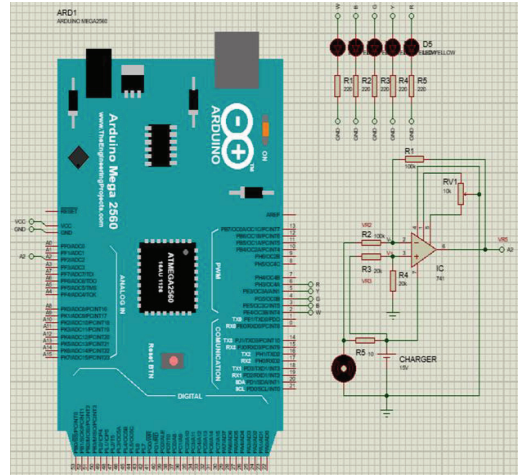

Fig. 2. Circuit diagram of the system

C. Hardware Prototype

Fig. 3 shows that the hardware created for the system. In this study, the hollow cardboard was assumed to represent the very clean air filter in which nothing is blocking the air flow. The number of the sponges were assumed to be proportional to the level of the dirtiness on the air filter. For instance, the cardboard incorporated with 3 sponges was assumed to represent the air filter with high dust level. Table I shows the dust level status in conjunction with the above conditions and their respective LED indicator by means of different LED color.

TABLE I
THE DUST LEVEL AND THEIR RESPECTIVE LED INDICATOR.

Air Filter Blockage	Dust Level	LED Indicators
Hollow cardboard	Very Low	White
Hollow cardboard + 1 Sponge	Low	Blue
Hollow cardboard + 2 Sponges	Normal	Green
Hollow cardboard + 3 Sponges	High	Yellow
Hollow cardboard + 3 Sponges + Cardboard	Very High	Red

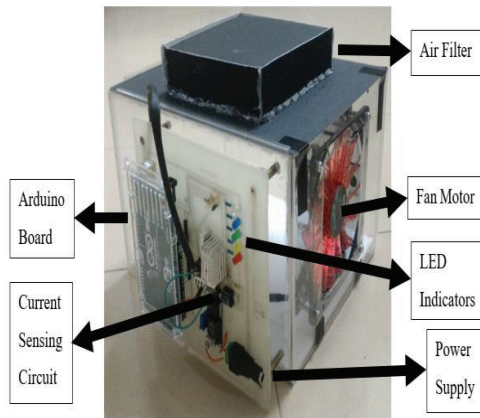

Fig. 3. Hardware of the system

D. Simulink Model

Fig. 4 shows that the Simulink model of the system. The ADC values of current, I is first passed through a series of noise removal process. The median filter is used to remove the spikes from the current signal whereas the moving average block was used to smooth the current signal. The values were then passed through the fuzzy logic controller to generate the dust level that represented by LED indicators. The first step for the fuzzy logic controller was to set I as the input variable and to set the dust level as the output variable. The second step was to set the Mamdani rule style fuzzy inference system (FIS) properties. The third step was to set the membership function for I and dust level, respectively. The last step was to set the rules for the system conditions as shown in Fig. 5.

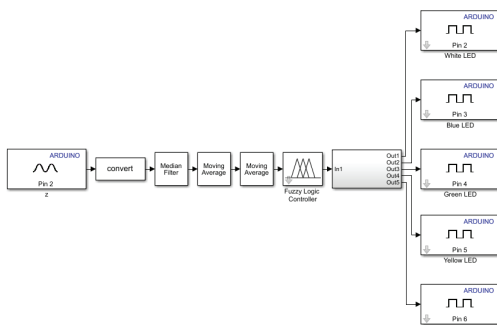

Fig. 4. Simulink model of the system

1. If (I is Very_Small) then (Dust_Level is Very_Low) (1)
2. If (I is Small) then (Dust_Level is Low) (1)
3. If (I is Normal) then (Dust_Level is Normal) (1)
4. If (I is Large) then (Dust_Level is High) (1)
5. If (I is Very_Large) then (Dust_Level is Very_High) (1)

Fig. 5. Rules for system conditions

E. System Design

Fig. 6 illustrates the flowchart of the system operation. Firstly, the power supply was switched on. Secondly, the current was automatically sensed and passed through the fuzzy logic controller. From the fuzzy logic controller, if the current was very small, then the dust level would be assumed to be very low. Consequently, the white LED would be turned on. If the current was small, then the dust level would be considered low, and the blue LED would be turned on. If the current was normal, then the dust level would be considered to be normal, and the green LED would be turned on. If the current was large, then the dust level would be considered high, and the yellow LED would be turned on. Lastly, if the current was very large, then the dust level would be considered very high, and the red LED would be turned on.

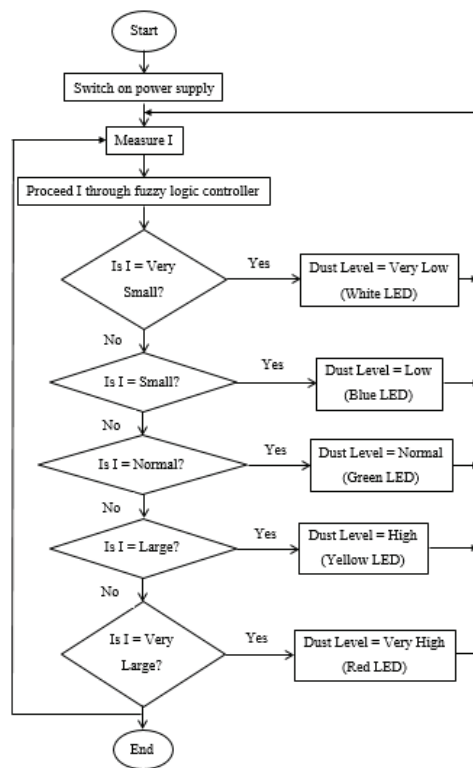

Fig. 6. Flowchart of the system operation

IV. Results and Discussion

A. Signal Noise Reduction and Smoothing

Signal noise reduction and smoothing is to discover the important patterns in the current data while to remove the unimportant signals. One goal is to produce

slow changes in value so that we can observe the trends in the current data. Fig. 7 shows that the original noisy signal. The original noisy signal exhibits many unwanted transients or spikes. In order to eliminate the unwanted transients or spikes, median filtering that is a natural way was used. Median filtering replaces every point of the original noisy signal by the median of that point and a number of neighboring points which is the window length, $N_1 = 10$. Accordingly, it discards points that considerably differ from their surroundings. Fig. 8 shows that the acquired signal after noise reduction and smoothing by using the median filter. By comparing the Fig. 7 and Fig. 8, results show that the median filter vanishes the unwanted transients or spikes. To have a better and smoother signal, two moving average filters were used with $N_2 = 100$ and $N_3 = 80$, respectively. Both of the moving average filters took the average of every 100 and 80 consecutive samples of the signals, respectively. Fig. 9 shows that the signal after applying two moving average filters that were able to significantly remove unwanted signals.

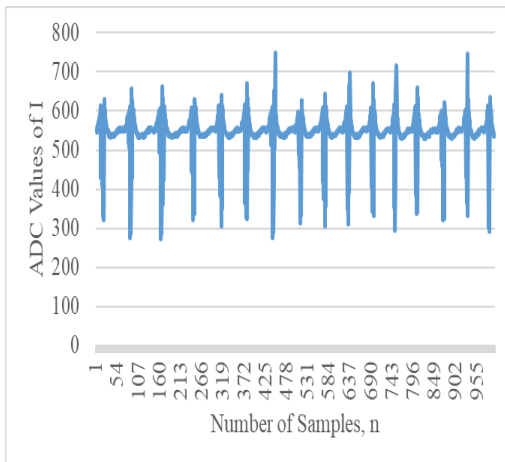

Fig. 7. Original noisy signal

Fig. 10 shows the graph of ADC values of I against the number of samples, n. About 10,000 data for the ADC values of I are collected for each dust level at the sampling time with 0.01s.

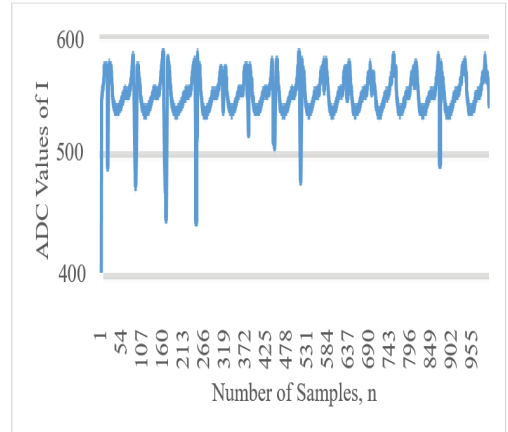

Fig. 8. The signal after median filtering

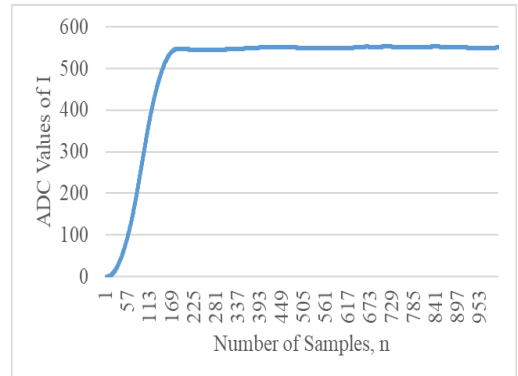

Fig. 9. The signal after applying moving average

B. Relationship between Current of Fan Motor and Air Filter Blockage Condition

From the Fig. 10, the ADC values of I for the very low dust level were in the range of 561 to 570; the ADC values of I for the low dust level were in the range of 569 to 577; the ADC values of I for the normal dust level were in the range of 576 to 581; the ADC values of I for the high dust level were in the range of 578 to 584; the ADC values of I for the very high dust level were in the range of 584 to 593. Table II shows the minimum, the mean and the maximum ADC value of I for each dust level. The lowest value of the current was 0.2742A for no air filter blockage whereas the highest value of the current was 0.2898A for full air filter blockage. Fig. 11 illustrates the average ADC value of I for each dust level. The results obtained shows that the current of the fan motor is proportional to the level of the air filter blockage.

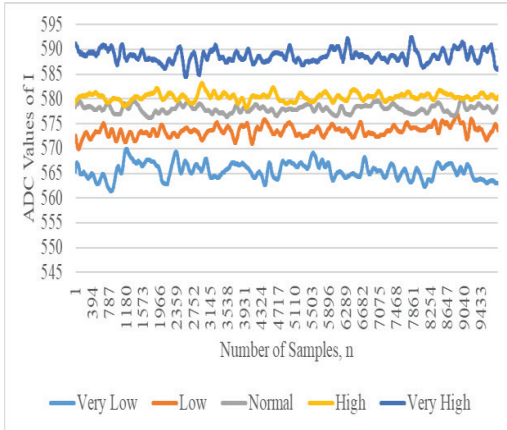

Fig. 10. ADC values of I against the number of samples, n

TABLE II
MINIMUM, MEAN AND MAXIMUM ADC VALUE OF I FOR EACH DUST LEVEL

Dust Level	ADC Value of I		
	Minimum	Mean	Maximum
Very Low	561	566	570
Low	569	574	577
Normal	576	578	581
High	578	580	584
Very High	584	589	593

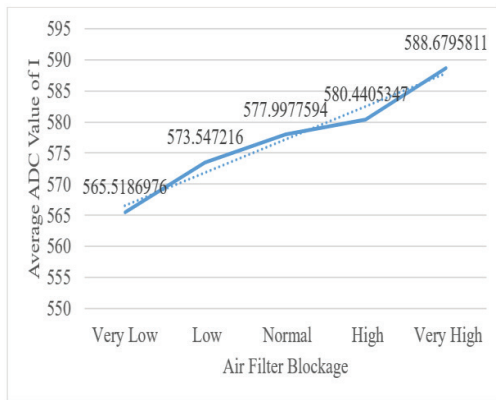

Fig. 11. Average ADC value of I against air filter blockage

C. Evaluation of System Performance on Hardware

The sensed current of the fan motor of the system was calibrated first due to the series of the signal noise reduction and smoothing process. Then, the sensed current was then passed through the fuzzy logic controller. The fuzzy logic controller was used to determine which LED would be turned on by negotiating the nonlinear range between two neighborhoods dust level.

When the sensed current lies within the range of the ADC value of the current which is from 561 to 570 and almost all the time maintained at the mean ADC value

of the current which is 566, the white LED turned on. The white LED represents no air filter blockage performed by a hollow cardboard. The system with very low dust level would turn on the white LED.

When the sensed current lies within the range of the ADC value of the current which is from 569 to 577 and almost all the time maintained at the mean ADC value of the current which is 574, the blue LED turned on. The blue LED represents 25% air filter blockage performed by one sponge that placed on the hollow cardboard. The system with low dust level would turn on the blue LED.

When the sensed current lies within the range of the ADC value of the current which is from 576 to 584 and almost all the time maintained at the mean ADC value of the current which is 578, the green LED turned on. The green LED represents 50% air filter blockage performed by two sponges that placed on the hollow cardboard. The system with normal dust level would turn on the green LED.

When the sensed current lies within the range of the ADC value of the current which is from 578 to 584 and almost all the time maintained at the mean ADC value of the current which is 580, the yellow LED turned on. The yellow LED represents 75% air filter blockage performed by three sponges that placed on the hollow cardboard. The system with high dust level would turn on the yellow LED.

When the sensed current lies within the range of the ADC value of the current which is from 584 to 593 and almost all the time maintained at the mean ADC value of the current which is 589, the red LED turned on. The red LED represents full air filter blockage performed by the combination of one cardboard and three sponges that placed on the hollow cardboard. The system with very high dust level would turn on the red LED as illustrated in Fig. 12.

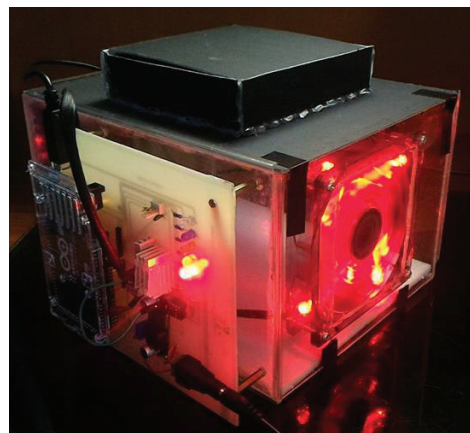

Fig. 12. The system with very high dust level (red LED)

V. Conclusion

The proposed air filter dust level sensing system was successfully designed using Ohm's law and fuzzy logic controller. The fuzzy logic controller was designed as a rules-based system to determine the air filter dust level. The system contains a current sensing circuit that was designed and developed by using a subtracting amplifier and Ohm's law. The sensed current from the DC motor was passed through the fuzzy logic controller to determine the dust level.

The finding indicates that the current is proportional to the air filter blockage. The lowest value of the current was 0.2742A for no air filter blockage whereas the highest value of the current was 0.2898A for full air filter blockage. The dust levels were classified as very low, low, normal, high, and very high dust levels that were indicated using white, blue, green, yellow, and red LEDs, respectively. The proposed system is promising to be applied to automatically sense the dust level without human visual inspection.

Acknowledgements

Authors would like to acknowledge Universiti Tun Hussein Onn Malaysia for providing facility support for the study, and Nor Fathen Nasohah Binti Kosman's assistance to the project.

References

- [1] "Saving Money and Staying Cool. A Guide to Air Conditioner Maintenance." Interstate Air Conditioning & Heating, 2015. [Online]. Available: <http://www.interstateair.com/guide-to-air-conditioner-maintenance/>. [Accessed 12 December 2017].
- [2] "Innovate Malaysia 2018," Daikin Malaysia Sdn Bhd, 2017. [Online]. Available: http://innovate.dreamcatcher.asia/page_02dk.html. [Accessed 11 December 2017].
- [3] N. R. E. L. (NREL), Energy-Efficient Air Conditioning, United States: U.S. Department of Energy (DOE), 1999.
- [4] M. A. Mokheimer, S. Hussain, M. D. Nadeem and A. A. M. Abdulrahman, "Production Cost-Efficiency Relation for Room Air Conditioners and Its Economic and Environmental Impact," *Journal of Energy Resources Technology*, vol. 139, no. 6, 2017.
- [5] C. Y. Lin, G. R. Crossman and A. K. Verma, "An Air-Filter Sensor for Home-Used Air Conditioners," in *American Society for Engineering Education, Norfolk, 2003*.
- [6] I. Daut, M. Adzrie, M. Irwanto, P. Ibrahim and M. Fitra, "Solar Powered Air Conditioning System," *Energy Procedia*, vol. 36, pp. 444-453, 2013.
- [7] A. B. Altayeva, B. S. Omarov and Y. I. Cho, *International Journal of Fuzzy Logic and Intelligent Systems*, vol. 16, no. 4, pp. 254-261, 2016.
- [8] F. Chabni, R. Taleb, A. Benbouali and M. Amin Bouthiba, "The Application of Fuzzy Control in Water Tank Level Using Arduino," *International Journal of Advanced Computer Science and Applications (IJACSA)*, vol. 7, no. 4, pp. 261-265, 2016.

