

Evaluation of Distribution Network Modelling for Electric Vehicle Charging Impact

Muhammad Faz'zri Abdullah¹, Ser Lee Loh^{2*}, Chin Kim Gan³ and Dennis Ling Chuan Ching⁴

²Advanced Manufacturing Centre (AMC)

^{1,3}Center for Robotics and Industrial Automation (CeRIA)

^{1,2,3}Fakulti Kejuruteraan Elektrik, Universiti Teknikal Malaysia Melaka.

⁴Faculty of Science and Information Technology, Universiti Teknologi Petronas,
Seri Iskandar, 32610 Perak, Malaysia

*corresponding authors: slloh@utem.edu.my

Abstract – *Electric vehicle (EV) is a new and uprising technology in the transportation and power sector that benefits the economy and environment. This study presents a comprehensive review of electric vehicle technology and its associated equipment, such as battery charger and charging station. An introduction is made on the residential charging type of electric vehicles in terms of charging time, size of battery and power of charger. The influence of electric vehicle charging on utility distribution system in terms of voltage and thermal limits are investigated in this paper. The current power system may not able to support the EV charging loads. The usage of electric vehicles, customer power consumption behavior and the distribution of electric vehicle used in a residential area may affect its power system structure. To study the influence of EV charging in a power distribution system, analysis were conducted based on these three factors. Firstly, the new network will be simulated using all the standard parameter for residential. Secondly, the EV load will be inserted into the network based on different scenarios of EV's penetration level and the investigation will be carried out to study the impact of EV on the distribution network in terms of voltage and thermal limits. It is found that the higher penetration level of EV charging will lead to the higher voltage drop and feeders' thermal limit.*

Keywords: *Charging Station; Electric Vehicle; Network Distribution; Rechargeable Battery*

Article History

Received 17 January 2018

Received in revised form 24 January 2018

Accepted 30 January 2018

I. Introduction

Nowadays, the use of EVs technology is growing worldwide. The goal of this innovation has been triggered by the United States as their country has rapidly developed the usage of electric cars in everyday life. Since year 2010, a total of 50,000 electric cars have been sold in the United States and this makes United States a country that actively encourage the use of this electric car technology. The development of this technology has also been highlighted by other European countries and United Kingdom.

Through the market, there are 8844 stations of electric vehicle across the United States that include public and private areas that are mostly concentrated in California. The use of EVs charging in residential has also been driven by the increased use of electric cars due to an estimation of nearly 200,000 electric cars have been sold there [1]. The growth of this technology has also gains attention from other countries and it leads to the high

demand on EVs charging facilities for residential area in general.

The development of the EVs market in Malaysia has been achieved through the cooperation of BMW Group Malaysia and Malaysian Green Technology Corporation (Green Tech Malaysia) at the 7th International Greentech & Eco Products Exhibition and Conference Malaysia (IGEM) on 5th October 2016. In this context, the charging station network has been spearheaded by Green Tech Malaysia in creating a consistent use of EVs. Due to the development of new technologies in Malaysia, effective strategies have been designed to expand and enhance consumer confidence in the services provided.

In addition, the implementation target to install EVs charging facilities have been drawn up by the parties involved, especially at the more developed locations such as Kuala Lumpur, Johor, Selangor and Melaka. Meanwhile, Malaysia also plans to create more EVs charging station with a target of 25,000 base stations to support the marketing of EVs to reach 100,000 units

within the next 5 years from year 2016 [2].

Petronas Dagangan plans to install 100 EV charging stations at its stations nationwide by 2018 and this announcement was made at the 8th International Greentech & Eco Products Exhibition & Conference Malaysia (IGEM 2017). This initiative is expected to demonstrate the continued installation in the long term based on set targets to promote and encourage consumers about the advantages of the new technology that will penetrate the mobile market in Malaysia [2].

EV is getting popular and the battery of EV is advanced where it can be charged through electricity grid. Hence, there is a need to investigate the impact of EV implementation on the new network design of distribution system in residential area. This project aims to investigate the power network problem regarding to the voltage and thermal limits on feeders in residential area with the implementation of EV charging. In this case, DigSILENT Software is used to run the load flow followed by the investigation of the impact of EV on the feeders in distribution network system based on different scenarios of EV's load penetration level.

The other objectives of this research are to design a new distribution network for residential area and to investigate the impact of electric vehicle charging on feeders in terms of voltage and thermal limits.

This project will focus on the new network of residential area. Several scenarios are chosen by following the penetration level of EV load to analyze the impact of EV implementation onto the new network distribution system by using DigSILENT Software.

II. Literature Review

Plug-in Electric Vehicle (PEV) has been used for EV variant. The advantages of the PEV are in terms of the excess energy grid that can be saved and the ability to support the grid during peak system, better known as a vehicle to grid (V2G) [3][4]. In addition, in terms of weakness, PEV depends heavily on battery costs and limited driving range. PEV battery charging will cause a major disruption to the existing grid system. In the study, the process of reviewing the relationship between the rate charged and the charging of different charging the grid system in the next 24 hours based on the load profile of the existing system is reviewed.

PEV charging period can significantly increase the pressure on the grid system supplied to local residence [5][6]. The use of PEV in residential area can cause some side effects, equipment failures, voltage fluctuations and peak load new system that is more potent in increasing disruption to the grid system in the residence. In the meantime, loss of power generation system and distribution may be affected significantly by PEV charging.

The main capacity of a power distribution network is to supply electricity to the end-utilize clients to meet their energy demand at voltage levels below that of

transmission systems. In North America, the appropriation frameworks work at various voltage levels including 34.5 kV, 23.9 kV, 14.4 kV, 13.2 kV, 12.47 kV, 4.16 kV and others [7]. To perform a more accurate assessment of the impact and pressure of PEV charging on the grid, realistic distribution grid topology is implemented. The impact on the residential network considered by some LV 415V (240V) and unlike the existing analysis, LV represents different neighborhoods real system data. Figure 1 shows the example of grid system distribution network [8].

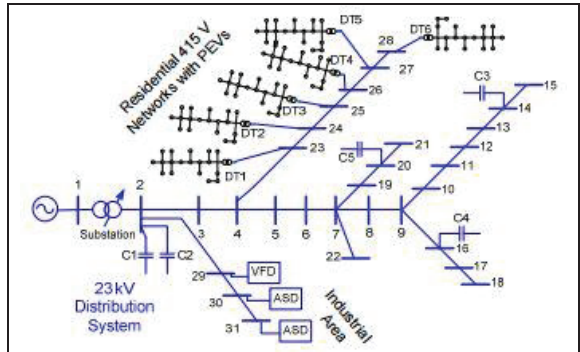

Fig. 1. Example of 23 kV distribution feeder with several 19 nodes 415V residential networks and high penetration of PEVs

To model the PEV charging, the capacity of battery is important to determine reasonable charging profiles [8]. PEV battery chargers should be evaluated sufficiently high to charge batteries of these sizes in sensible eras. However, the constraints of household unit wiring must be considered. A standard single-stage 240V outlet (Australia) can commonly supply a most extreme of 2.4 kW. There are also 15A and 20A outlets which are single phase and three phases that can supply around 4 kW and 14.4 kW. In analysis, 80% of the evaluated battery life is accepted useable bringing about an accessible limit of 12.8 kWh that the charger must deliver. Battery chargers also have some losses and the energy form grid should be greater than the stated battery capacity. The energy of 14.2 kWh is required from the grid to charge a single PEV by assuming 90% the approximate efficiency of battery charger [9].

The use of electric vehicle technology also affects the low voltage distribution network impressed in terms of breaches of voltage, voltage unbalance, thermal limits feeder and transformer thermal limits has been assessed [10]. Higher penetration of EVs charging leads to higher voltage drop and unbalanced if the power system network is not well restructured for EV charging use. As a result, feeder and the transformer can easily reach their thermal limits. To penetrate the market in Malaysia, investigation based on different EV charging scenarios should be carried out to ensure a sufficient supply in electricity distribution network for EV charging at residential area.

Other than that, for PEV charging occurring during the peak time zone, the voltage deviations are increased if compared to larger time zone charging periods. In this investigation, PEVs are randomly located and time scheduled within the allowable period. For high penetration of PEVs, significant overloads are experienced by local distribution transformers. Transformers overloads are not uncommon and are often tolerated for peak times, especially due to seasonal load loading patterns such as heavy air conditioning usage. However, particular PEV charging patterns result in extreme overloads that will significantly deteriorate the life time of the transformer.

Therefore, this study will focus on the impact of PEV charging systems for grid configuration in LV networks in residential areas. The impact on system performance review includes a profile grid voltage, loss of power system, the peak demand as well as transformer loading in this system.

III. Research Methodology

To design this distribution network, the related parameters are considered by following their standard rating of power supply and transformer rating. Figure 2 shows the new load flow that was configured by using DigSILENT Software. Next, a load was installed at each feeder by assuming its distance at 0.05 km. The load flow of new distribution network that equipped with EVs charging will be sketched and run by using DigSILENT Software.

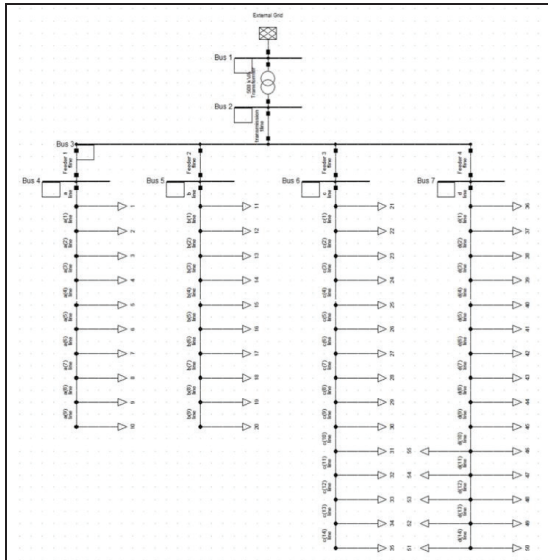

Fig. 2. New Network of 7 bus and 55 load distribution network with 500 kVA Transformer Rating

This new network uses a 7 bus and 55 load distribution networks consist of four levels of radial feeders [11].

Bus 4, 5, 6 and 7 are the residential loads. For residential load, it is assumed to use 0.9 of power [12], [13]. In this network, it used 11 kV of phase voltage and it also assumed a balance of three phases network system. To run this load flow, the distances between each two loads are used to design the size of feeders as shown in Table 1, the type and cable size that used in this network are also shown in Table 2 and basic parameter that will be used in this network is shown in Table 3.

TABLE I
DISTANCES USED FOR EACH LINE SEGMENT AT FEEDERS

From	To	Length (km)	From	To	Length (km)
Bus 2	Bus 3	0.3	25	26	0.05
Bus 3	Bus 4	0.1	26	27	0.05
Bus 3	Bus 5	0.1	27	28	0.05
Bus 3	Bus 6	0.1	28	29	0.05
Bus 3	Bus 7	0.1	29	30	0.05
Bus 4	1	0.05	30	31	0.05
1	2	0.05	31	32	0.05
2	3	0.05	32	33	0.05
3	4	0.05	33	34	0.05
4	5	0.05	34	35	0.05
5	6	0.05	Bus 7	36	0.05
6	7	0.05	36	37	0.05
7	8	0.05	37	38	0.05
8	9	0.05	38	39	0.05
9	10	0.05	39	40	0.05
Bus 5	11	0.05	40	41	0.05
11	12	0.05	41	42	0.05
12	13	0.05	42	43	0.05
13	14	0.05	43	44	0.05
14	15	0.05	44	45	0.05
15	16	0.05	45	46	0.05
16	17	0.05	46	47	0.05
17	18	0.05	47	48	0.05
18	19	0.05	48	49	0.05
19	20	0.05	49	50	0.05
Bus 6	21	0.05	50	51	0.05
21	22	0.05	51	52	0.05
22	23	0.05	52	53	0.05
23	24	0.05	53	54	0.05
24	25	0.05	54	55	0.05

TABLE II
CABLE TYPE AND SIZE [14], [10]

Branch	Type of Cable
Bus 2 to Bus 3	4 x 500 mm ² PVC/PVC AL
Bus 3 to Bus 4, 5, 6, 7	185 mm ² 4C AL XLPE
Connection Bus 4, 5, 6, 7 to-node	Aerial Bundle Cable (ABC) 3 x 185 mm ² + 120 mm ² AL

For this research paper, EV load will be penetrated to the residential load distribution network. To complete this project, the investigation on sufficient power supply needed which provides a stable condition is being carried out since condition of thermal limits will give an impact

to the distribution network system when EV load charging is penetrated to the residential load. Therefore, the simulation of EV load distribution network for residential area will be constructed by using DigSILENT Software and all parameters that are used in this new design network are shown in Tables 1-3. Next, the impact of EV charging will be investigated.

TABLE III
BASIC PARAMETER FOR NEW DESIGN NETWORK (FROM TNB)

Parameter	Value
Incoming Supply	11 kV
Residential Voltage	400 V
Power Factor	0.9 lagging (assume)
Double Storey Maximum Demand (Urban)	5.0 kW

For this research paper, EV load will be penetrated to the residential load distribution network. To complete this project, the investigation on sufficient power supply needed which provides a stable condition is being carried out since condition of thermal limits will give an impact to the distribution network system when EV load charging is penetrated to the residential load. Therefore, the simulation of EV load distribution network for residential area will be constructed by using DigSILENT Software and all parameters that are used in this new design network are shown in Tables 1-3. Next, the impact of EV charging will be investigated.

IV. Results and Discussion

Six simulation cases were done and parameters such as voltage, current and power are obtained. Parameters for each of the scenarios are processed and plotted into graph. Minimum voltage is used to ensure voltage limit does not violate from its standard range. Maximum current is used to determine the thermal limit of feeder. Total power was calculated to find out the transformer loading. Six scenarios were investigated on the effect of normalized load demand and when the EV charging was injected into this new network such as without EV load; 0% and 20%, 40%, 60%, 80% and 100% of EV load were injected to each feeder. From the graph of voltage, current and total active power, it shows one line which 0% for network with normal load while another five lines which 20%, 40%, 60%, 80% and 100% indicates the penetration level of EV load into this new network. All the scenarios were investigated regarding to the impact of EV load charging to this network before and after injected to the each feeder.

A. Normal Load Demand in New LV Network Modelling

The performance of new network without EV load is designed by using DigSILENT Software. Figures 3 and 4 show the normalized load demand for each feeders and total active power for normalized load demand respectively. Besides that, there are the minimum voltage in per unit that is shown respectively in Figure 5. There

are 4 types of graph line that indicate 4 types of feeder. In this case, red and yellow line indicates the performance of 10 houses in normal load at Feeder 1 and 2, respectively. For blue line, it shows the performance of 15 houses in normal load at Feeder 3. Meanwhile for green line, it shows the performance of 20 houses in normal load at Feeder 4. Even the load is approximately the same, but the cable will be longer when there are more houses. The line impedance of the cable will cause the voltage drop and thermal limit to enlarge when length of cable is longer. A 230 V of voltage was used in this case and for thermal limit, there was limit for a cable to carry. In this case, feeder uses 185mm² cables. According to TNB, 320A is the limit for 185mm² cable [14]. Total power consumed should not exceed the rating of transformer connected.

Figure 3 shows the normalized load demand of each feeder in a new distribution network. This graph indicates load demand pattern before EV charging on distribution network.

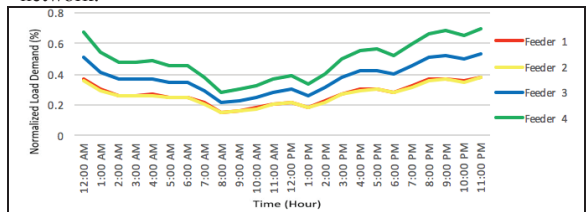

Fig. 3. Normalized Load Demand of Each Feeder

Figure 4 shows the total load active power per 24-hour for each feeder on this distribution network.

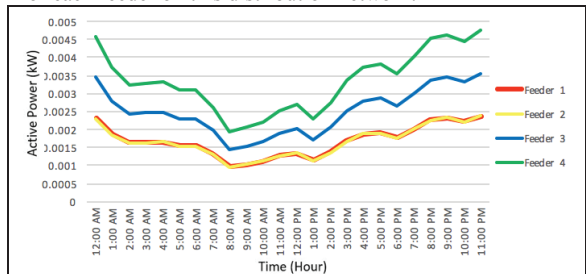

Fig. 4. Total Load Active Power of Each Feeder

Figure 5 shows the voltage of each feeder before EV is charging on distribution network. Voltage at Feeder 1 and 2 are same because it consists of same number of houses in each feeder.

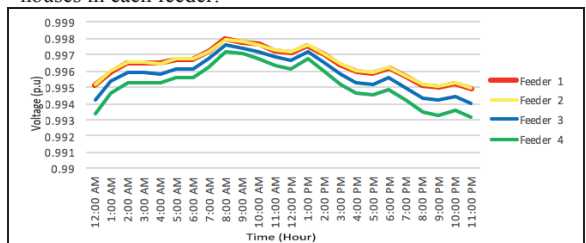

Fig. 5. Voltage of Each Feeder

B. EV's Load and Charging Profile Modelling

In this case, all the EV load started charging from 10 pm until 4 am. Based on the Malaysian routine, the residents went out to work at 8 am and return to home at 5 pm. After that, they rest and spend time with family before bed time at 10 pm. At the same time, PEV is suitable to be charged at home at around 10 pm until 4 am for Nissan Leaf EV type because it takes around 6 hours for full charging. Table 4 shows the slot time for EV charging time at home that is used in this case.

TABLE IV
SLOT TIME FOR EV'S CHARGING TIME IN HOUR

Hours	AM						PM					
	12	02	04	06	08	10	12	14	16	18	20	22
EV's Charging time	EV	EV	EV									EV

The results in graph based on the penetration level of EV load to each of the feeders. The black line, 0% indicates the normal voltage without EV load and the rest of color lines in graph indicate the injection of EV load to each of the feeders at the penetration level of 20%, 40%, 60%, 80% and 100%, respectively. During the time, when EVs are charged at home, the voltage at each of the feeders in this LV network are unbalance because of voltage drop occurred.

Figures 6 to 9 show the voltage limit at each of the feeders when EV load is injected which voltage drop is occurred. The increasing of load will cause the voltage drop and the current will increase at each of the feeder. Figure 6 shows the voltage increase at Feeder 1.

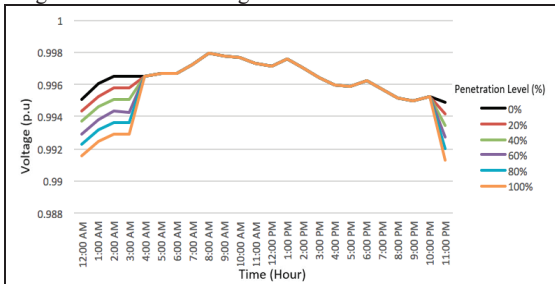

Fig. 6. Voltage at Feeder 1 with EV Penetration Level

Figure 7 shows the voltage increase at Feeder 2. Voltage at Feeder 1 and 2 are same because it consists of same load with 10 houses of each feeder.

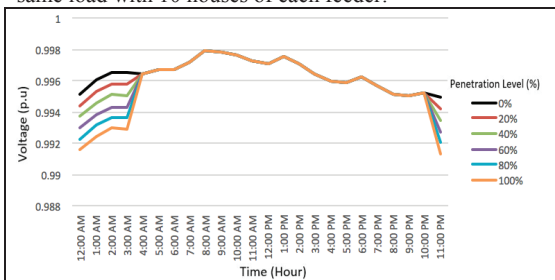

Fig. 7. Voltage at Feeder 2 with EV Penetration Level

Figure 8 shows the Feeder 3 was facing the highest voltage drop because it consists of highest amount of houses (15 houses) compared to Feeder 1 and 2 respectively.

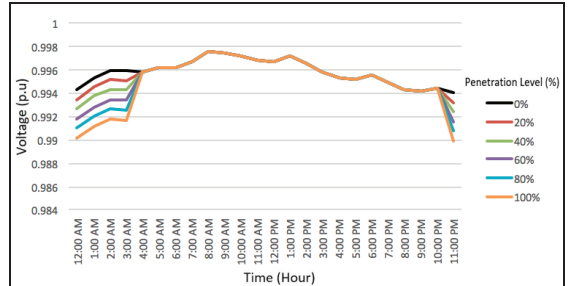

Fig. 8. Voltage at Feeder 3 with EV Penetration Level

Figure 9 shows the Feeder 4 was facing the highest voltage drop because it consists of highest number of houses (20 houses) compared to the other feeders in this new distribution network system.

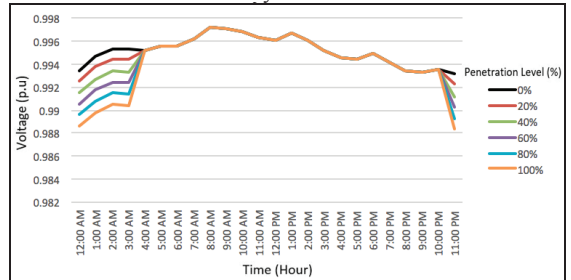

Fig. 9. Voltage at Feeder 4 with EV Penetration Level

At the same time, Figures 10 to 13 show the maximum current on each feeder. The increasing of current occurs when EV load is applied to the house. It is show that when voltage is increase, current also will be increase. The highest current drawn for all feeder was on 10 pm. Since 10 pm was peak load demand, most power will be consumed at that hour and thus current drawn will also increase.

Figures 10 and 11 show the same value of current which starts increasing when 20% to 100% of EV penetration level are used on distribution network. Both feeders consist of 10 houses respectively.

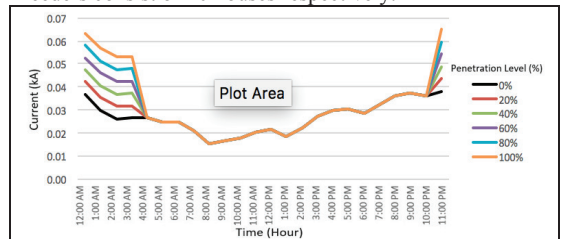

Fig. 10. Current at Feeder 1 with EV Penetration Level

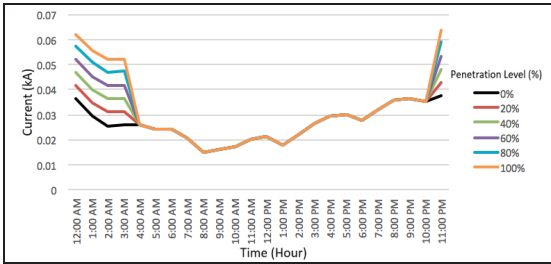

Fig. 11. Current at Feeder 2 with EV Penetration Level

Figure 12 shows current value at Feeder 3 is the highest if compared to Feeder 1 and 2. This is because in this case, Feeder 3 consists of 15 houses.

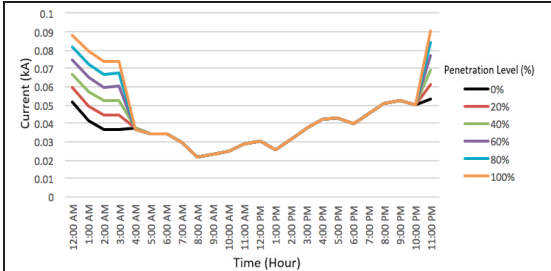

Fig. 12. Current at Feeder 3 with EV Penetration Level

Figure 13 shows the highest current compared to other feeders because it has 20 houses on this feeder.

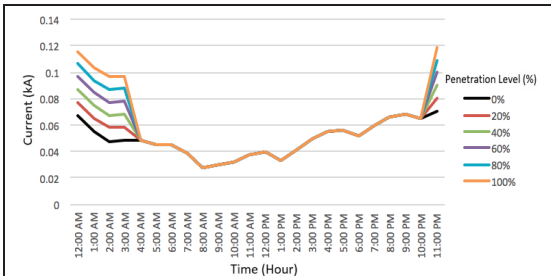

Fig. 13. Current at Feeder 4 with EV Penetration Level

Figures 14 to 17 show the total active power of each feeder in this LV network regarding to the normal load (black line) and with EV load (the rest of line graphs) that indicates penetration level of EV load.

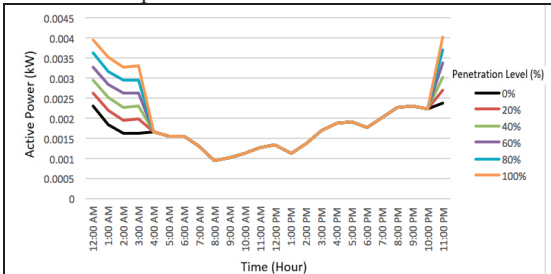

Fig. 14. Total Active Power at Feeder 1 with EV Penetration Level

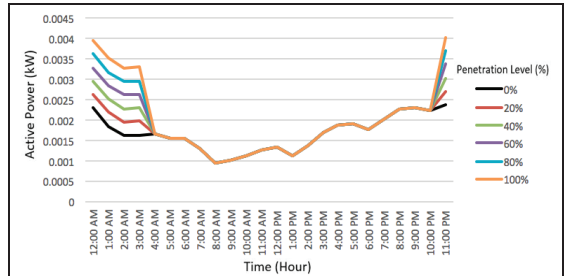

Fig. 15. Total Active Power at Feeder 2 with EV Penetration Level

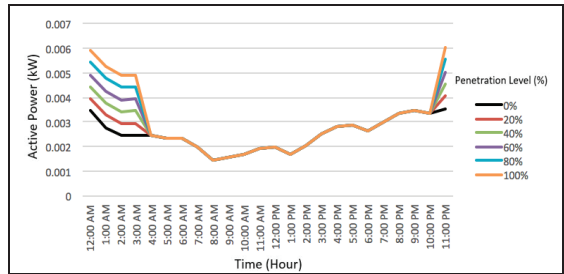

Fig. 16. Total Active Power at Feeder 3 with EV Penetration Level

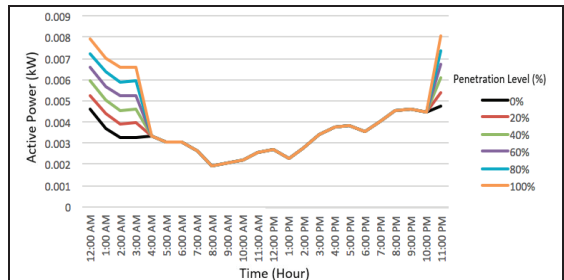

Fig. 17. Total Active Power at Feeder 4 with EV Penetration Level

In summary, the value of total active power starts to increase at Feeder 3 and become the highest value at Feeder 4 on each feeder if compared to all the feeders available in this distribution network.

Figure 18 shows the voltage at different feeders for a particular time. This shows that higher penetration level of EV charging will lead to the higher voltage drop.

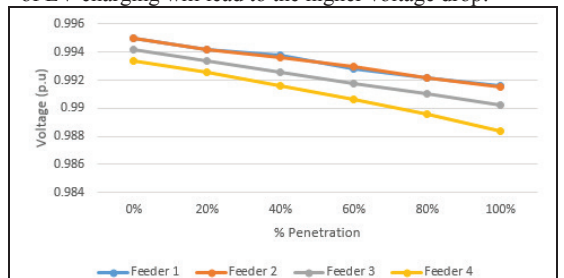

Fig. 18. Voltage drop at different feeders

Figure 19 shows the maximum transformer loading when EV charging is used on distribution network system. This graph is illustrated in percentage of transformer loading and rating of transformer that was used is 500 kVA. This transformer will be in normal condition which is able to operate within its life time because it does not exceed the limit and will not burst.

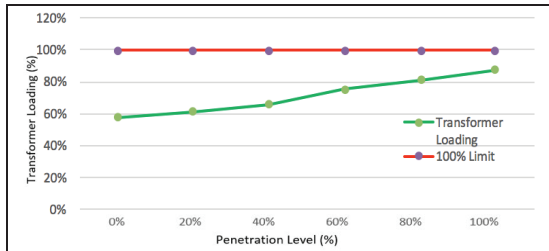

Fig. 19. Transformer Loading with Penetration Level of EV Charging

Figure 20 shows the threshold current of each feeder with EV penetration level. Based on this graph, the current is not exceeding its limit of 320 A at each of the feeder. For that, the cable size that is used for each feeder is suitable and able to operate in normal condition without any problems.

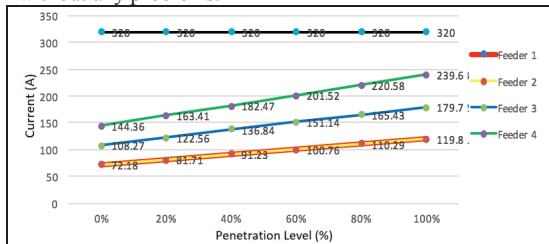

Fig. 20. Threshold Current of Each Feeder

V. Conclusions

The impacts of EV charging to the LV distribution network in terms of voltage and feeders thermal limit were evaluated. A new model of LV distribution network system was designed to run the load flow and investigate the impact of EV charging on residential area with the different scenarios of EV penetration level such as 0%, 20%, 40%, 60%, 80% and 100%. This project was carried out to the balanced EV connection.

The results of different scenarios were shown in result section. It can be concluded that the higher penetration level of EV charging will lead to the higher voltage drop and feeders' thermal limit. The feeder thermal limit was not exceeded because it still operates in normal condition with under limit of range.

For the improvement of this project, it can be analyzed further on the impact of EV charging on distribution network for residential area with the case of unbalanced EV connection in the future work.

Acknowledgements

The authors would like to thank the Universiti Teknikal Malaysia Melaka for their financial funding through high impact PJP grant PJP/2017/FKE/H111/S01536.

References

- [1] P. Bansal, Charging of Electric Vehicles: Technology and Policy Implications, *Zanyvl Krieger School of Arts and Sciences, Johns Hopkins University, Washington DC, JSPG., Vol. 6, (Issue 1), February 2015.*
- [2] C. Y. Choo, Malaysia Commits to Green Tech with Electric Car Charger Network, *Nikkei Asian Review, Edition 2016, October 7, 2016.*
- [3] A. Ipakchi and F. Albuyeh, Grid of the future, *IEEE Power and Energy Magazine, Vol. 7, 52-62, 2009.*
- [4] P. Fairley, Speed bumps ahead for electric-vehicle charging, *IEEE Spectrum, Vol. 47 (no. 1), 2010.*
- [5] M. A. S. Masoum, P. S. Moses and S. Deilami, Load management in msart grids considering harmonic distortion and transformer derating, *Proc. International Conference on Innovative Smart Grid Technologies (ISGT), 1-7, 2010.*
- [6] K. Clement-Nyns, E. Haesen and J. Driesen, The impact of charging plug-inhybrid electric vehicles on a residential distribution grid, *IEEE Transactions on Power Systems, Vol. 25, 371-380, 2010.*
- [7] W. H. Kersting, *Distribution system modeling and analysis*, New Mexico: (CRC press, 2012).
- [8] K. Clement-Nyns, E. Haesen and J. Driesen, The impact of charging plug-in hybrid electric vehicles on a residential distribution grid, *IEEE Transactions on Power Systems, Vol.25, 371-380, 2010.*
- [9] S. Shetty, *Impact of PEV charging loads on distribution system operations and optimal siting and sizing of PEV charging stations*, Electrical and Computer Engineering, University of Waterloo, Ontario, Canada, 2015.
- [10] C. H. Tie, C. K. Gan, K. A. Ibrahim, The Impact of Electric Vehicle Charging on a Residential Low Voltage Distribution Network in Malaysia, *IEEE Innovative Smart Grid Technologies - Asia (ISGT ASIA), 272-277, 2014.*
- [11] J. Dickert and P. Schegner, Residential Load Models for Network Planning Purposes, *Modern Electric Power Systems*, (Wroclaw, Poland, 2010).
- [12] T. K. Au, *Assessment of Plug-in Electric Vehicles Charging on Distribution Networks*, Electrical Engineering, University of Washington, 2012.
- [13] P. Moses, S. Deilami, M. Masoum, Power quality of smart grids with plug-in electric vehicles considering battery charging profile", *EEE PES innovative smart grid technologies, 1-7, 2010.*
- [14] Distribution Division, Tenaga Nasional Berhad, *Electricity Supply Application Handbook*, (Third Edition, November 2011).

